



---

# Soil compaction and deformation in forest exploitation

---

A literature review on causes and effects and guidelines on avoiding compaction and deformation

---



---

Jasprina Kremers & Martijn Boosten

---

Wageningen, December 2018





---

# **Soil compaction and deformation in forest exploitation**

---

A literature review on causes and effects and guidelines on avoiding compaction and deformation

---

---

Jasprina Kremers & Martijn Boosten

---

Wageningen, December 2018



# Colophon

© Stichting Probos, Wageningen, December 2018

**Authors:** Jasprina Kremers & Martijn Boosten

**Title:** Soil compaction and deformation in forest exploitation  
A literature review on causes and effects and guidelines on avoiding compaction and deformation

**Publisher:** Stichting Probos  
Postbus 253, 6700 AG Wageningen, the Netherlands  
tel. +31 (0)317-46 65 55  
[mail@probos.nl](mailto:mail@probos.nl)  
[www.probos.nl](http://www.probos.nl)

**Commissioned by:**  
Staro Natuur en Buitengebied



**With financial support of:**  
Bosgroep Midden Nederland  
Bosgroep Zuid Nederland  
FSC Nederland  
Het Flevo-landschap  
Gemeente Bergeijk  
Gemeente Cranendonck  
Klingen bomen  
Kroondomein Het Loo  
Stichting Probos  
Rijksvastgoedbedrijf  
Staatsbosbeheer

- Copying, reproducing or publishing (parts) of this publication is permitted provided that the source is clearly indicated.
- Copying, reproducing or publishing is not permitted for those parts of this publication where it is clear that the copyrights are with third parties and / or are reserved.
- Stichting Probos accepts no liability for any damage resulting from the use of the results of this research or the application of advices or recommendations in this publication.



## Preface

There is a growing awareness among forest managers that the use of machines in forest operations can have negative consequences on the forest soil, causing soil compaction and deformation. Together with other organisations in forest management and research institutes Staro Natuur en Buitengebied wants to explore soil-saving forest exploitation methods. To map the existing knowledge on the effects of forest exploitation on the forest soil, Staro commissioned this literature review.

The authors hope that this literature review will provide forest managers with new knowledge on this topic. We also hope this report will contribute to a broad discussion in the forest sector on the effects of forest exploitation on the soil and how to protect and preserve forest soils during forest exploitation.

We would like to thank Daniël Joppe (Staro Natuur en Buitengebied) for his help in finding literature, his review of the first draft of this report and his constructive support in the process of writing the report. Also, we would like to thank Erwin Al (Staatsbosbeheer), Wouter Delorterie (Bosgroep Midden Nederland), Jan den Ouden (Forest Ecology and Management Group, Wageningen University), Erik van der Staak (Staro Natuur en Buitengebied), Etiënne Thomassen (Bosgroep Zuid Nederland) and Maarten Willemen (AVIH) for their critical review of the first draft of this report.

Jasprina Kremers & Martijn Boosten

Wageningen, December 2018





# Contents

<b>1</b>	<b>Introduction</b>	<b>9</b>
<b>2</b>	<b>Soil compaction and deformation and its causes</b>	<b>11</b>
2.1	Compaction vs deformation	11
2.2	Factors influencing soil compaction and deformation	14
2.2.1	Soil characteristics	14
2.2.2	Weather conditions	16
2.3	Soil compaction in The Netherlands	18
<b>3</b>	<b>Consequences of soil compaction and deformation</b>	<b>19</b>
3.1	Effect on the forest ecosystem	19
3.1.1	Effects on gas exchange in the soil and hydrology	19
3.1.2	Effects on tree roots and rooting ability	21
3.1.3	Effects on soil biodiversity and nutrient availability	22
3.1.4	Effects on forest regeneration and growth	23
3.1.5	Effects on flora and fauna	24
3.2	Economic effects	24
3.3	Effects on recreational and cultural values	25
<b>4</b>	<b>Recovery after soil compaction and deformation</b>	<b>27</b>
4.1	Natural soil recovery	27
4.2	Measures to facilitate recovery	28
<b>5</b>	<b>Forest exploitation and soil compaction and deformation</b>	<b>31</b>
5.1	Machine characteristics	31
5.1.1	Calculating machine ground pressure	31
5.1.2	Machine weight	32
5.1.3	Machine track types	33
5.1.4	Slipping control	40
5.1.5	Machine velocity	41
5.2	Frequency of machine movements	41
5.3	Determining optimal exploitation conditions	41
5.4	Permanent skid roads	44
<b>6</b>	<b>Conclusions and recommendations</b>	<b>45</b>
6.1	Conclusions	45
6.2	Recommendations	46
<b>7</b>	<b>References</b>	<b>47</b>



# 1 Introduction

Every year an average of 1 million m<sup>3</sup> of industrial round wood is harvested in the Dutch forest. In most harvest operations the use of machines is common practice. There is a growing awareness among forest managers that the use of machines in forest operations can have negative consequences on the forest soil. Heavy machines can cause soil compaction and deformation. This may lead, among other things, to degradation of soil structure, reduction of the soil's water storage capacity, lack of oxygen in the soil, death of fine roots and reduced rooting, all impacting biodiversity and forest productivity. In addition, heavy machines can create deep ruts in the forest soil. These ruts are not appreciated by recreational visitors and contribute to the negative image of timber harvesting.

Although the awareness is growing there is a general lack of knowledge in the forest sector on the (exact) impact of forest exploitation machines on the soil. Also, practical knowledge on how to prevent or counteract negative effects of forest exploitation on the forest soil is missing. For instance, it is unclear which forest soils are more vulnerable to soil compaction and how weather conditions influence soil compaction. Other questions are: What is the maximum allowable soil pressure? Which machines and exploitation methods can be used to minimize soil compaction and deformation?

Staro Natuur en Buitengebied, consultants in forest and nature, wants to explore new soil-saving forest exploitation methods in association with other partners in forest management and research from the Netherlands and the neighbouring regions of Flanders (Belgium) and North Rhine-Westphalia (Germany). As a first step, Staro commissioned Probos to conduct a literature review in order to map the existing knowledge on the effects of forest exploitation on the forest soil.

The aim of this literature review is to compile and create insight in the effects of forest exploitation on the soil for both forest managers and policy makers. The document must also provide insight into the preconditions that new forest exploitation methods and techniques must meet in order to ensure no or minimal soil compaction and soil deformation.

The literature review aims to answer the following questions:

- What is soil compaction and deformation and on what scale does it occur?
- What are the consequences of soil compaction and deformation?
- Which factors influence the extent to which soil compaction and deformation occurs?
- How does natural soil recovery take place after compaction or deformation?
- Are there guidelines on how to avoid soil compaction and deformation during forest exploitation?



## 2 Soil compaction and deformation and its causes

### 2.1 Compaction vs deformation

Felling and hauling of trees cause wounding of the soil. This kind of soil disturbance is mostly limited to disturbance of the litter layer and superficial disturbance of the mineral soil layer (O and A horizon), having little and only briefly impact on the forest ecosystem. (Ampoorter *et al.*, 2010; Goris, 2018). However, heavy forestry machines (for example harvesters, forwarders and tractors used as shredders or mulchers) can cause more thorough forms of soil disturbance like soil compaction and soil deformation, leaving deep ruts in the forest soil. When assessing the impact of forest machinery on the soil a distinction must be made between soil compaction and soil deformation.

Compression of soil pores under the weight of the wheels is called soil compaction. Subsoil layers (soil layers beneath the topsoil, see fig. 2.1) are pressed together densely due to the pressure applied to the topsoil layers (A and/or O horizon). This causes breakdown of the soil's structural aggregates and machine tracks are printed into the soil, creating ruts (fig. 2.2, example A). This form of soil disturbance changes not only soil density and penetration resistance, but even the soil's hydrological properties. The soil can become so dense that water stagnates in the ruts. The risk of subsoil compaction is highest when forces exerted by forestry machines are higher than the bearing capacity of the subsoil. (Alakukku *et al.*, 2003; Ampoorter *et al.*, 2010; Allman *et al.*, 2015; De Schrijver *et al.*, 2018).

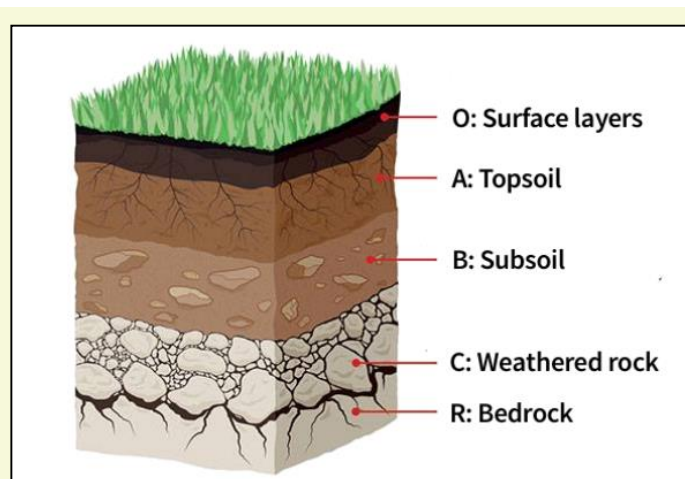

**Figure 2.1**

General classification of soil layers. (Source: <http://soilsensor.com/soil-types>)

When pores cannot be compressed, forces applied by the machine's wheels or tracks push the soil sideways instead of down, creating smaller compacted ruts but leaving heaps of accumulated subsoil next to the wheel tracks. This is called soil deformation (fig. 2.2, example C) (De Schrijver *et al.*, 2018). Distinct cases of soil deformation typically occur on very wet clay and loamy soils (Ampoorter *et al.*, 2010). Heubaum (2015) describes soil deformation as an exceedance of the soil's shear strength. The shear strength of a soil is the amount of shear

stress (pressure put on the soil) a soil can resist. Up to this amount of pressure, the soil is still able to keep together all soil particles. When shear strength is exceeded, soil deformation occurs.

Combinations of these two types of soil damage occur as well. For example, on moist clay or loamy soils, or on dry sandy soils, where part of the machine forces is turned into soil compaction and part is turned into soil displacement, causing deformation (fig. 2.2, example B) (Ampoorter *et al.*, 2010; (De Schrijver *et al.*, 2018).

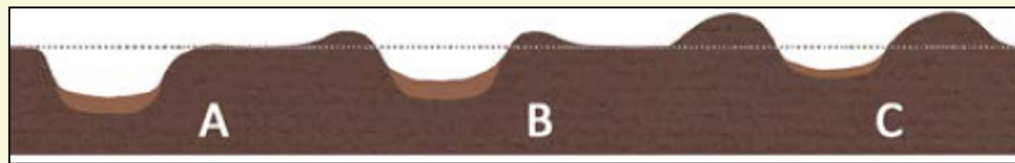

**Figure 2.2**

*Soil compaction and deformation.*

*A) soil compaction underneath wheel track, B) soil compaction and soil deformation, C) soil deformation.*  
(Source: De Schrijver *et al.*, 2018)

The level of soil disturbance can vary from slight to heavy. An often-used classification is that of Lüscher (Lüscher, 2010; Lüscher *et al.* 2010). Lüscher made a classification of rut types to indicate the level of soil disturbance in comparison to an undisturbed soil. Figure 2.3 and table 2.1 present an overview of these rut types and the degree of soil disturbance.

This classification is based on three characteristics of soil physics: soil density, saturated water permeability and pore volume. For example, in rut type 3, soil density is three times higher than in a reference situation. The hydraulic conductivity differs significantly between the three rut types and the reference situation. For rut type 3, hydraulic conductivity is even 10-30 times smaller than the reference situation. Changes in pore volume occur as well. In his experiment, for rut type 3 Lüscher (2010) found a reduction in pore volume at 15-20cm soil depth from 55% compared to the reference situation.

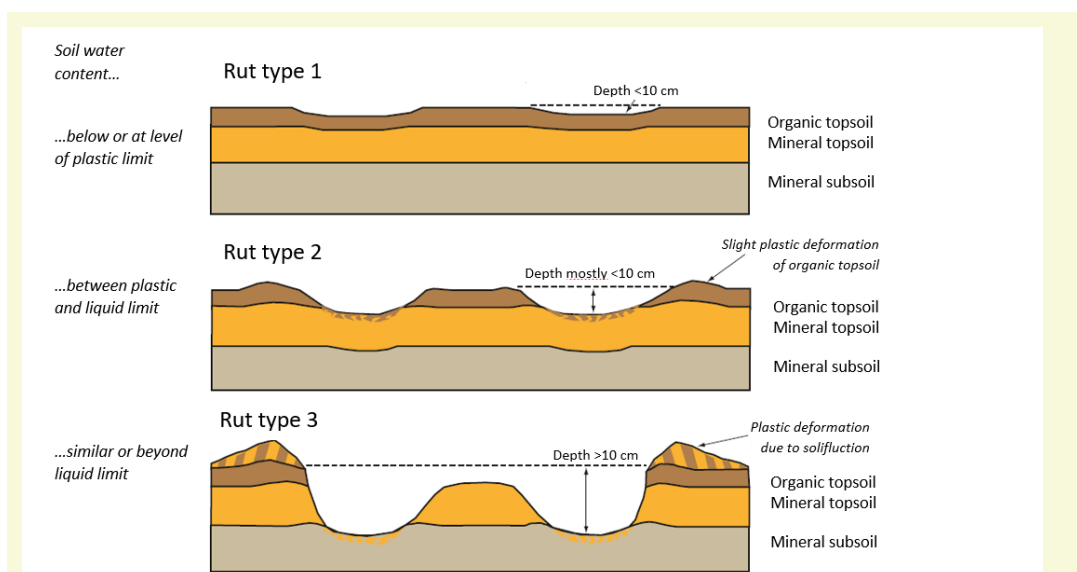

**Figure 2.3**

*Rut types and their main characteristics as distinguished by Lüscher *et al.* (2010)*

**Table 2.1***Rut types and their main characteristics as distinguished by Lüscher (2010)*

Criterion	Rut type 1 (slightly disturbed soil)	Rut type 2 (moderately disturbed soil)	Rut type 3 (heavily disturbed soil)
Rut depth	5 to max. 10 cm (in top soil)  Slight printing of wheel tracks in organic layer	< 10 cm  Slight plastic deformation, clear deepening of max. 10 cm in A horizon	> 10 cm  Disturbance reaches subsoil, clear plastic deformation alongside wheel tracks.
Composition top soil	Not disturbed	Slightly disturbed	Disturbed
Deformation	None	Slightly present	Distinctively present

Another example of a classification of soil disturbance levels is the Weyerhaeuser system, used in the Pacific Northwest of the United States, which distinguishes five disturbance classes (figure 2.4) Heninger *et al.* (2002).

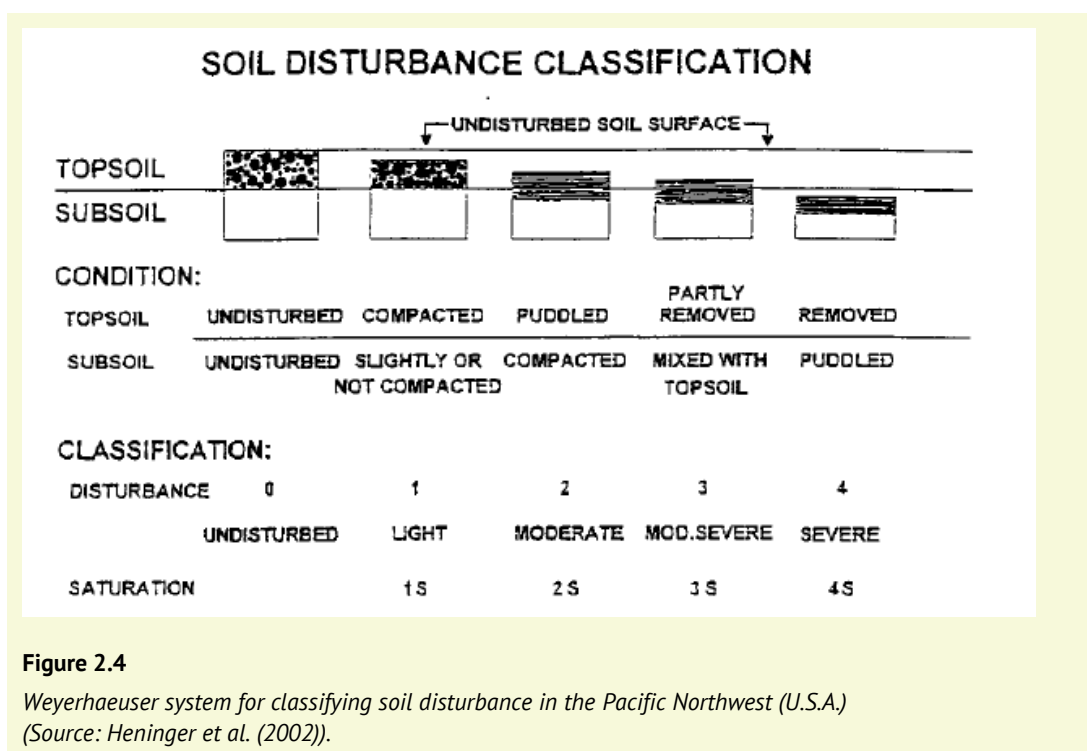

Labelle and Jaeger (2011) noticed in their field study that soil compaction does not only occur at the actual moment of machine traffic. They found that bulk density increased even up to 26 months after machine traffic. As a possible explanation for this phenomenon they indicated that the clearing of trees during harvesting caused increased solar radiation and temperature on these trails. This could have increased the rate of biological activity and the decomposition

of organic matter originating from the sheared off or dead roots. The decrease of organic matter content could explain the rising of soil density long after machine traffic. Although unsure about the mechanism behind it, Naghdi *et al.*(2018), too, observed further increases in soil surface compaction and decreases in macro porosity one year after skidding, compared to levels immediately after skidding.

## 2.2 Factors influencing soil compaction and deformation

Soil compaction and deformation occur during forest exploitation with heavy machinery due to complex interactions of soil pressure, shearing forces and vibrations into the soil. The amount of soil pressure exercised is determined by the weight of the forestry machine per area of contact with the soil surface (called the 'footprint' area (Ireland, 2006)). Shearing forces occur through driving and steering of forestry machines and slipping of their wheels. Vibrations into the soil are caused by the machine's motor and movements. These effects do not only occur right underneath the machine but can also influence the soil up to 0.75 meter sideways of wheels as the stress exerted underneath the machine is distributed diagonally into the soil (Labelle and Jaeger, 2011; De Schrijver *et al.*, 2018). Labelle and Jaeger (2011) presume that presence of a root network might contribute to this sideways dispersion of soil disturbance by acting as a medium to distribute received loadings outside of the actual soil pressure contact area. According to Ampoorter *et al.* (2007), compaction effects are most distinct in the upper 20 cm of the soil.

According to Arnup (1999) soil susceptibility to compaction is defined by the magnitude of applied machine contact pressure, soil moisture content, the share of rock and sand particles, soil structure, bulk density of the soil, soil porosity and thickness of the topsoil. Also, weather conditions, machine characteristics, the forest exploitation interval and frequency of machine movements determine the level of compaction. The main soil characteristics that influence the susceptibility to compaction are discussed in paragraph 2.2.1. Paragraph 2.2.2 contains an overview of weather conditions that affect soil compaction. The influence of machine characteristics and exploitation method are further discussed in chapter 5 'Forest exploitation and soil compaction and deformation'.

### 2.2.1 Soil characteristics

Initial soil density plays an important role in susceptibility to compaction. Looser soils have more macro pores, which are easy to compact. In denser soils, pores are smaller, which makes them more resistant to further compaction (Ampoorter *et al.*, 2010A). Figure 2.5 shows an example of the effect of machine traffic on an already compacted sandy soil and a looser clay soil with initially low penetration resistance, found in the study of Ampoorter (2011B) on forest soils in Flanders.



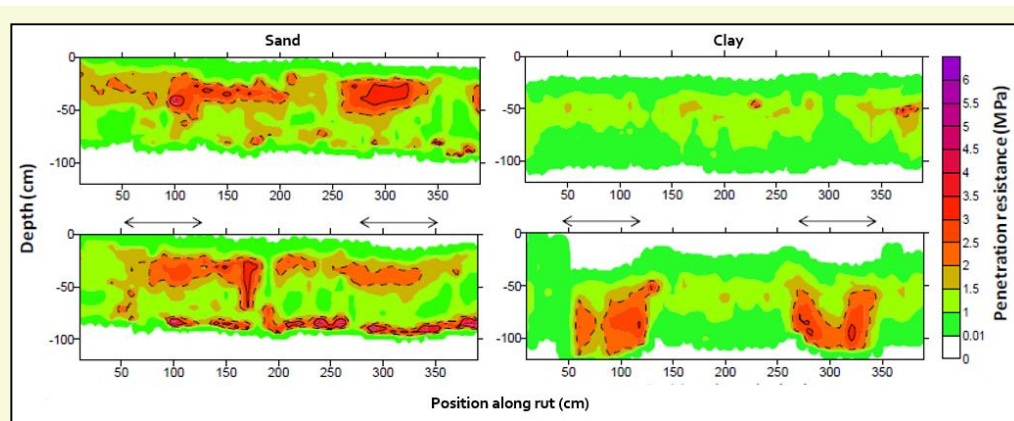

**Figure 2.5**

Initial soil density (above) and the effect of five skidding cycles (below) with a skidder loaded to 14.3 ton on already compacted sandy soil (left) and initially loose clay soil (right). The increase in penetration resistance (in MPa) was limited on the already compacted sandy soil. However, on the initially loose clay soils, clear compaction and deformation can be seen and clear increases in penetration resistance under the wheel tracks was measured. The horizontal black arrows indicate the position of the machine's wheel tracks after passage. At penetration resistance levels of 2 MPa, root growth slows down, and exceeding 3 MPa, it stops. (Source: Ampoorter, 2011B)

The occurrence of soil compaction and soil deformation mainly depends on soil texture, stone content of the soil, the amount of organic matter in the soil and soil moisture content (De Schrijver *et al.*, 2010; Lüscher *et al.*, 2016).

In general, the finer the soil texture (i.e. the finer particles in the soil), the more susceptible the soil is to compaction and plastic deformation (Sutherland, 2003; Labelle and Jaeger, 2011; Lüscher *et al.*, 2016). The ratio between compaction and deformation depends on the soil water content (Ampoorter *et al.*, 2010A). In general, the wetter the soil, the more susceptible the soil is to disturbance and the more plastic deformation occurs due to machine traffic (Lüscher, 2010).

In fine textured soils like clay rich soils (>40%<sub>v</sub> clay), under dry conditions, particles are bound together strongly, giving the soil more resistance to soil compaction and deformation. These soils are most susceptible for compaction under intermediate soil moisture contents and least susceptible under dry soil conditions. When these soils are saturated, all pores are filled with water and cannot be compressed. However, in this situation cohesion between particles is minimal, leaving the soil little ability to withstand machine pressures and very susceptible to soil deformation. Pores in these soils are well able to hold water against gravitational forces. It is bound securely in the small pores, which makes these soils dry out more slowly than coarser textured soils. Therefore, after a period of rain, it takes more time for the soil to be driveable again. (Howard *et al.*, 1981; MacNabb and Boersma, 1993; Hillel, 1998; Lüscher *et al.*, 2016; De Schrijver *et al.*, 2018).

Although generally it is assumed that more coarsely textured soils, like sand and loamy sand, are less susceptible to soil compaction, it is important to note that these soils too can suffer from compaction and deformation. Due to the larger particle size, there is more space between particles, which is more difficult to compact than with finer particles. At high soil moisture contents, cavities between soil particles are filled with water and cannot be compressed. However, coarse sandy soils also contain larger pores that have more difficulty in retaining water. Even at high soil moisture contents, these pores are partly still filled with air. Which

means that under wet circumstances soil compaction and deformation can still occur (Fisher and Binkley, 2000; Ampoorter, 2011; De Schrijver *et al.*, 2018).

With very low soil moisture contents in coarsely textured soils, cohesion between soil particles is reduced, making compaction and deformation easy to occur as well. An intermediate soil moisture content is optimal for coarsely textured soils to create the least amount of damage. (De Schrijver *et al.*, 2018). Coarsely textured soils are most resistant to compaction at a soil water content of about 12% due to capillary forces, maximum cohesion and aggregation of particles. (Ampoorter *et al.*, 2010A).

Allman *et al.* (2015), in their study, found maximum compaction levels for soil moisture contents between 12 and 35% on all stands (with differing initial compaction conditions and soil textures).

**Table 2.2**  
*The effect of soil texture and moisture content on the susceptibility of soils to compaction and deformation*

Soil texture	Soil moisture content		
	Dry	Intermediate	Wet
Fine textured soils : Clay, loam	Low susceptibility to compaction and deformation	High susceptibility to compaction and deformation	Low susceptibility to compaction, but high susceptibility to deformation
Coarsely textured soils: Sand, Loamy sand	High susceptibility to compaction and deformation	Low susceptibility to compaction and deformation	Low susceptibility to compaction and deformation (except for very coarse soils)

Gravel particles (>2mm, e.g. pebbles and stones) play an important role as ‘skeleton’ of the soil. The higher the gravel content of the soil, the stronger the ‘skeleton’ and the better the soil’s resistance to compaction by heavy machinery. For soils with a gravel content of >50%<sup>1</sup>, it can be assumed that the risk of compaction is small (Lüscher *et al.*, 2016).

Also, the amount of organic matter in the soil also influences soil compressibility. Soils with higher organic matter contents are relatively less susceptible to soil compaction compared to similar soil types with lower organic matter contents (Labelle & Jaeger, 2011).

### 2.2.2 Weather conditions

Weather conditions affect the soil moisture and therefore influence the soil’s susceptibility to compaction and deformation. For instance, heavy rains will cause forest soils to become very wet, making them more susceptible to disturbance by heavy machines. Severe deformation can occur when machine traffic takes place on saturated soils (fig. 2.6).

Frost can cause the water in the soil to freeze, hence strengthening the soil structure. Frozen subsoils are the ideal circumstance for forest exploitation activities since soil damage through compaction and deformation is minimized (De Schrijver *et al.*, 2018). In the Netherlands, long and severe periods of frost barely occur. In winter, forest soils are very wet and occurring frost will only freeze part of the top soil. However, Schack-Kirchner (2010) states that even a frozen topsoil cannot protect the forest soil from very heavy machines. The top soil of the rut

<sup>1</sup> Volume percent

won't be compacted, but, if strong enough to withstand machine forces, will be pushed into the ground as a frozen solid plate, hence compacting the top- and subsoil underneath the frozen plate (see fig 2.7. If not strong enough, the ice film on the soil will be broken by heavy machines, causing severe deformation in the wet forest soil.



**Figure 2.6**

*Soil deformation caused by machine traffic on wet forest soil  
(Source: Lotte van Nevel, Ghent University.)*

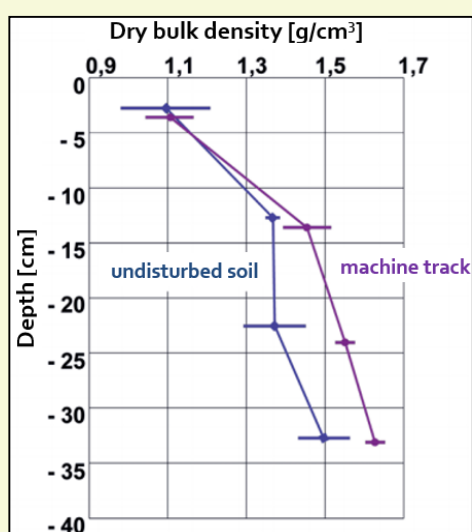

**Figure 2.7**

*The compaction effect of a frozen top soil on the soil below by driving with a 40-ton harvester with continuous tracks. Compaction in the rut takes place in the subsoil. (Source: Kietz et al., 2017)*

## 2.3 Soil compaction in The Netherlands

It is unknown to what extent soil compaction or deformation occurs in forests in the Netherlands. No data or field measurements are available. Only a rough estimate can be made of the amount of forest soil that is potentially affected.

Mechanization in forest exploitation started around the 1960s, 1970s (Thate, 1973) and in 1988, the first harvester was introduced in the Netherlands (De Baaij, 1999). By the end of the 20th century, forest exploitation by heavy machinery (harvesters, skidders, forwarders etc.) had become commonplace (Ampoorter *et al.*, 2010). For a long time, the general practice in forest exploitation was to drive randomly across the forest stands to harvest and haul trees. Only recently there is an increased trend in using fixed skid road in forest exploitation to preserve major parts of the forest soil. Skid roads are 4 m wide and are generally laid down at 20 m from each other (Goris, 2018). With this distance in between roads, 20% of the forest stands in which harvest takes place is being disturbed by machines (Potvliet and Delfortherie, 2016). The forested area in the Netherlands is 373,480 ha. According to the last National Dutch Forest Inventory in 43% of the forest area no harvest took place in the last 7 to 12 years (Schelhaas *et al.*, 2014; Clercx *et al.*, 2015). This means that 57% (=212,884 ha) of the forest area was recently harvested with machines<sup>2</sup>. Although it is not known under which weather and soil moisture conditions the harvest took place and which machines were used, a considerable part of the Dutch forest soil will be affected by forest operations.

A possible method of estimating the scale of forest soil compaction is by using a digital elevation model to trace down ruts created by forestry machines. For this purpose, the AHN (Actueel Hoogtebestand Nederland) could be used, a digital elevation model for the Netherlands on which even small elevational differences in the landscape are very well visible. As can be seen in figure 2.8, the ruts created in a forest stand during exploitation with machines are very well visible. This image shows that the AHN can be used to establish the presence of ruts in forests. However, it should be considered that these images do not tell anything about the age of the ruts or the amount of compaction and deformation consequences.

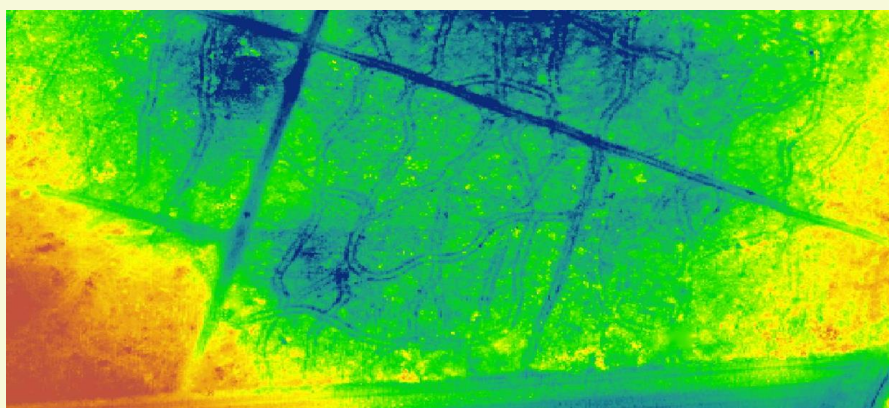

**Figure 2.8**

*AHN image of a forest stand in which exploitation with heavy machinery has taken place. As can be seen from the rut pattern, the machines have been driving randomly throughout the forest stand. (Source: Borgman Beheer Advies).*

<sup>2</sup> This corresponds to the forest area in the Netherlands that is designated as multifunctional forest with a timber production function. In the other part of the Dutch forest no harvest or a minimum amount of harvest takes place, because these areas are reserved for predominant natural, cultural or recreational goals.

## 3 Consequences of soil compaction and deformation

Soil compaction and deformation can have several effects on the forest ecosystem and the several forest functions (timber production, recreation and maintaining biodiversity). It also may affect archaeological and other heritage values in the forest (soil). Although in this chapter, chemical, ecological and productivity effects are discussed separately, it is important to note that these effects are all intertwined. Complex interactions between these aspects together form the forest ecosystem and shape the overall effect of machine traffic on the forest productivity, biodiversity and general vitality.

### 3.1 Effect on the forest ecosystem

#### 3.1.1 Effects on gas exchange in the soil and hydrology

Soil compaction leads to a decrease in (macro)pore volume (Herbauts *et al.*, 1996; Heninger *et al.*, 2002; Gebhardt *et al.*, 2009; Ampoorter *et al.*, 2010; Lüscher, 2010; Kietz *et al.*, 2017; De Schrijver *et al.*, 2018). Compaction can cause 50-60% of the macro-pores (pores > 50µm) to be broken down into meso-pores (0.2 - 50µm) and micro-pores (<0.2 µm) (Herbauts *et al.*, 1996). In addition, compaction also leads to destruction of pore continuity, increasing soil bulk density and decreasing soil porosity and air conductivity. Gas exchange between the soil and the atmosphere is hampered, which leads to an altered CO<sub>2</sub> and O<sub>2</sub> exchange between soil and atmosphere. This altered gas exchange can be problematic. Oxygen (O<sub>2</sub>), which is essential for soil life and chemical processes, cannot get into the soil and carbon dioxide (CO<sub>2</sub>) cannot get out. Low O<sub>2</sub> levels decrease the presence of soil life and limit growth of plants and trees. When O<sub>2</sub> concentrations drop below 6-10%, root growth of seedlings is reduced (Ampoorter *et al.*, 2010), hampering natural regeneration of the forest. (Goutal *et al.*, 2013; Herbauts *et al.*, 1996; Heninger *et al.*, 2002; Gebhardt *et al.*, 2009; Ampoorter *et al.*, 2010; Kietz *et al.*, 2017; De Schrijver *et al.*, 2018).

Compaction also means that, in general, less space is available to store methane (a strong greenhouse gas) in the soil, reducing forest soils' functionality as a methane sink compared to undisturbed soils. (Kietz *et al.*, 2017). Teepe *et al.* (2004) found reductions of soil CH<sub>4</sub> consumption up to 90% in compacted soils compared to undisturbed soils and, on silty clay loam sites, CH<sub>4</sub> was even released after compaction. For N<sub>2</sub>O (nitrous oxide, another greenhouse gas) they found up to 40 times increased emissions in wheel tracks compared to undisturbed soil.

Soil compaction can even lead to enhanced methane production within the soil. When, due to strong disturbance, O<sub>2</sub> levels decrease to less than 12%, soil bacteria species composition shifts in favour of bacteria adapted to anaerobic conditions. The increase of these bacteria species affects the growing conditions for trees. Also, the methane production within the soil increases as a result of an increase of bacteria (see fig. 3.1) (Frey, 2010).

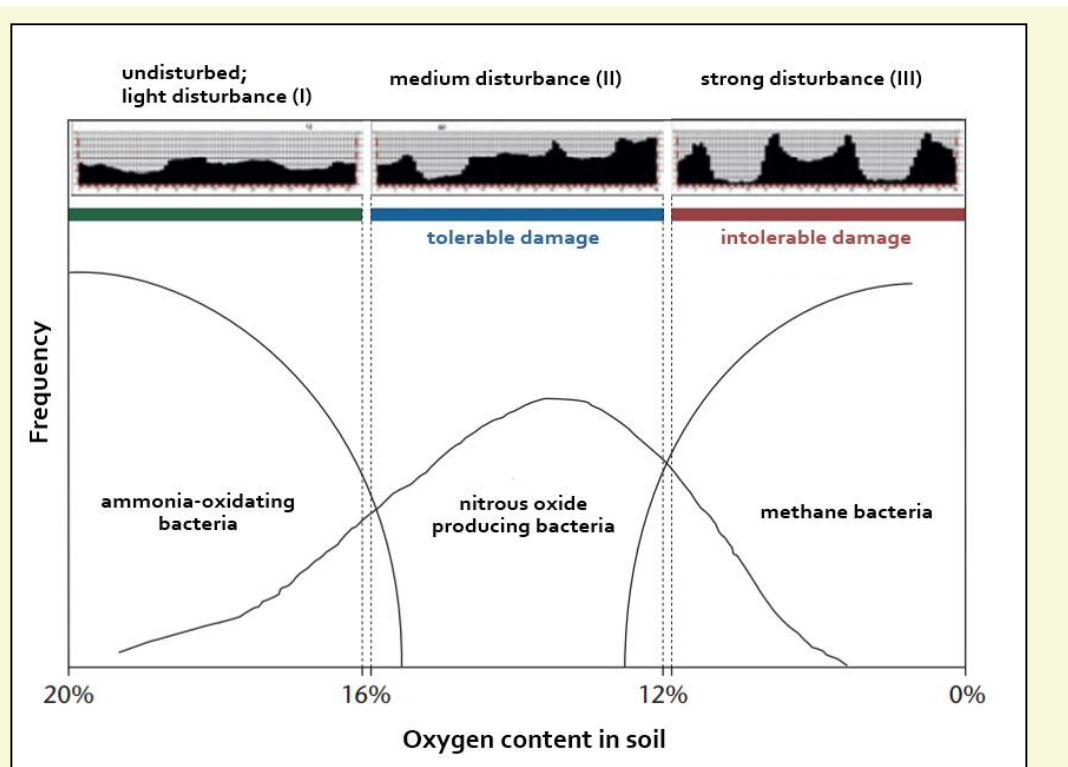

**Figure 3.1**

*Changes in bacteria population composition for different disturbance frequencies and decreasing soil oxygen contents (increasing compaction levels). Above: the visual classification of three types of soil damage. With medium disturbance and still tolerable damage; increase in nitrous oxide ( $N_2O$ ) producing bacteria at inadequate aeration of the soil. With strong disturbance and intolerable damage; a shift takes place from aerobic to anaerobic conditions, facilitating methane producing bacteria. Consequence; long-term decrease of soil fertility and no regeneration potential. (Source: Frey, 2010).*

Increased bulk density of soils also means that water conductivity can be obstructed (Halvorson *et al.*, 2003; Lüscher, 2010). In compacted soils the number of capillary pores, and hence water permeability, decreases (Halvorson *et al.*, 2003). Infiltration speeds can decrease up to 90%, from 11.4 cm/h in undisturbed soils to just 1.1 cm/h in compacted soil in ruts. Lüscher (2010) found 5-15% higher soil water contents within skid trails compared to undisturbed control sites.

Next to infiltration capacity of soils, compaction can decrease hydraulic conductivity of the soil. This means that water that gets into the soil cannot be transported to subsoil layers, keeping the soil saturated for a longer period, which obstructs gas exchange between soil and atmosphere. Some studies found a decrease of hydraulic conductivity up to 80%. (Dickerson, 1976; Potvliet, 2016).

Soil compaction can also cause formation of crusts on the soil surface, which reduce the soil's water absorption capacity and increase surface run-off (Malmer and Grip, 1990). Lousier (1990) found that machine traffic can increase the process of surface erosion by 2 to 15 times compared to the natural erosion rate. 85% of this erosion takes place in the first year after machine disturbance (Lousier, 1990).

### 3.1.2 Effects on tree roots and rooting ability

Several studies have shown that soil compression decreases rooting ability in soils due to smaller pore space, hampered gas exchange, less availability of oxygen (O<sub>2</sub>) and increased penetration resistance (Lüscher, 2010; Ampoorter, 2011B, Allman *et al.*, 2015). Due to increases in penetration resistance plants are less (or in some cases not) able to root in compressed soil. Aust *et al.* (1998) found that machine traffic can cause increases in penetration resistance of 30% to even 50% of initial resistance levels.

Arshad *et al.* (1996) found bulk density of soils to be limiting root growth when exceeding 1.47 g cm<sup>-3</sup> in clay soils, 1.75 g cm<sup>-3</sup> in silt soils and 1.80 g cm<sup>-3</sup> in loam and sandy soils (Ampoorter, 2011B). Lüscher (2010) measured soil density at two soil depths in the tree different rut types. Within the first 5-10 cm of soil, soil density was 1.05 g cm<sup>-3</sup> for undisturbed soil, 1.26 g cm<sup>-3</sup> in rut type 1 (slightly disturbed soil, see paragraph 2.1) and 1.33 g cm<sup>-3</sup> in rut type 3 (heavily disturbed soil). At a soil depth of 15-20 cm, measured soil densities were 1.10 g cm<sup>-3</sup> for undisturbed soil up to 1.41 g cm<sup>-3</sup> in rut type 3. Table 3.1 gives an overview of some critical soil bulk density values for root growth found in literature.

**Table 3.1**

*Critical soil bulk density values for root growth found in literature. At these soil bulk densities root growth will be limited.*

Source	Critical soil bulk density (g cm <sup>-3</sup> )
Arshad <i>et al.</i> (1996)	1.47 in clay 1.75 in silt 1.8 in loam and sand
Lüscher (2010)	1.41
Šimon & Lhotský (1989)	1.35-1.70
Lousier (1990)	1.2-1.4
Buchar <i>et al.</i> (2011)	1.3-1.7

Another factor that can be used to assess the impact of soil compaction on roots is the penetration resistance of the soil. Ampoorter (2007; 2012) showed that root growth is slowed down at penetration resistance levels of 2 MPa and is stopped when penetration resistance exceeds 3 MPa (Ampoorter *et al.*, 2007; Ampoorter, 2011B).

In undisturbed soils a homogeneous and dense structure of fine roots can in general be found in the upper 40 cm of soil. As shown in figure 3.2 soil compression can reduce root density of fine roots considerably and can even cause the disappearance of roots (Schäffer, 2002). Most compaction occurs in the top 30 cm of the soil; the layer in which most of the root biomass is situated (Allman *et al.*, 2015). However, the effect on roots is not limited to the top soil layer. It can occur in deeper soil layers as well, underneath and next to ruts (Schäffer, 2002). Labelle and Jaeger noticed increases of soil bulk density over 10% up to 1 m away from the tracks (Labelle & Jaeger, 2011)

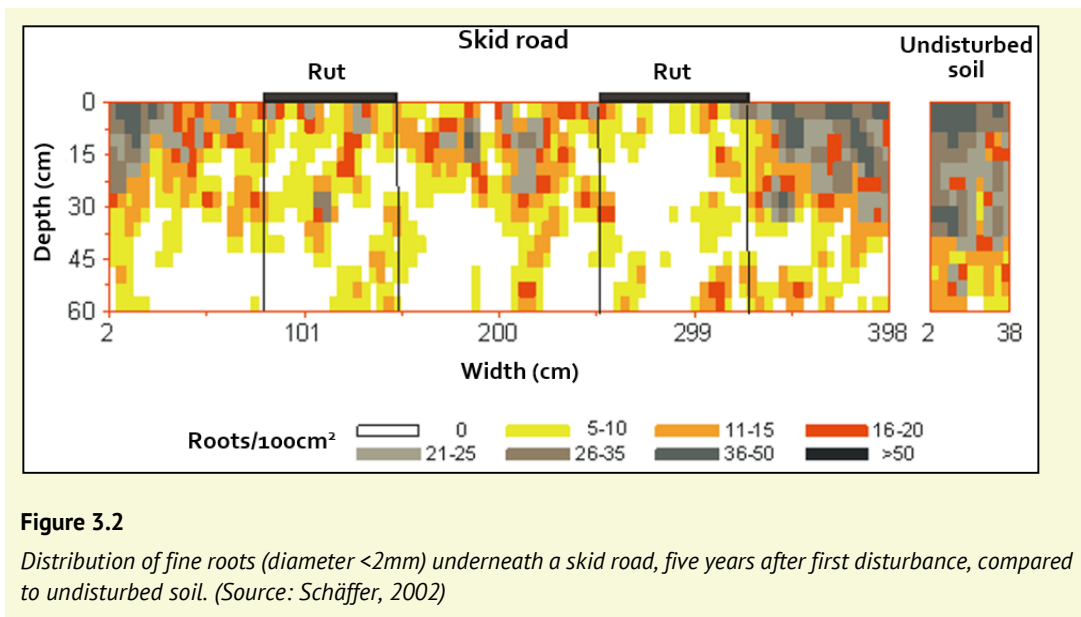

Soil compaction can also influence hormonal growth regulators in trees like ethylene (Tardieu Ruzicka *et al.*, 2007). Ethylene is a stress hormone which is produced when tree roots experience high penetration resistance in the soil. High amounts of ethylene hinder length growth of root cells, leading to relatively increased width growth of roots. Consequently, roots are less able to grow deep into the soil and will be less able to find water and nutrients needed for plant growth (Ruzicka *et al.*, 2007).

Due to soil deformation, deeper soil layers are brought to the surface of the forest floor. If tree roots in these layers are exposed to the forest floor, they can get damaged by forestry machines, which has a negative effect on the tree's productivity (De Schrijver *et al.*, 2018).

### 3.1.3 Effects on soil biodiversity and nutrient availability

Soil disturbance can have a negative impact on soil biodiversity, leading to decreased stand fertility, productivity and vitality on the long term (Ampoorter, 2011; Siepel, 2015). Cambi *et al.* (2017) showed that soil compaction decreased the qualitative biodiversity of soil microarthropods by 13%. The small oxygen levels and high density of compacted soils make it difficult for soil life, for example earthworms, mites and springtails to survive (Ampoorter, 2011; Siepel, 2015; De Schrijver *et al.*, 2018). These species have an important role in decomposition of organic matter and making nutrients available for plant uptake. Moreover, soil fauna - especially earthworms - are important for the improvement of soil structure. Therefore, a decrease in the amount of soil fauna can have direct and indirect consequences for all kinds of soil processes, and hence for forest productivity and soil recovering capacity after compaction (Siepel, 2015; De Schrijver *et al.*, 2018).

Lack of oxygen also causes problems for mycorrhizae, which have a symbiotic association with tree roots to obtain the energy needed for decomposition of organic material, from which in turn nutrients become available for tree roots to take up. Therefore, soil compaction can hinder nutrient uptake by trees through mycorrhizae and therefore effect forest productivity and vitality (De Schrijver *et al.*, 2018). In addition, the activity of microorganisms decreases with increasingly anaerobic conditions (Frey *et al.*, 2009), which leads to a loss of soil biodiversity and may indirectly influence forest (tree) vitality.



Besides the effects on nutrient uptake via mycorrhizae, soil compaction has negative effects on the absorption of minerals by the plant's root system. The low oxygen levels in compacted soils for example cause denitrification to occur, losing nitrogen as it evaporates during the process (Torbert and Wood, 1992). In a leaching experiment simulating long term impacts of forest operations, Arocena (1999) found that concentrations of nutrients in solution like  $\text{Ca}^{2+}$ ,  $\text{K}^+$ ,  $\text{Mg}^{2+}$  and  $\text{Al}^{3+}$  were lower in disturbed forest floors and compacted forest soils, hence decreasing the amount of nutrients available for plant uptake. Moreover, trees have difficulties taking up enough nutrients for growth under lower oxygen levels because oxygen is required to provide for the energy needed for transport and absorption processes within the plant. In this case accessibility of nutrients for trees is hampered twofold (Kozłowski, 1999) affecting tree growth and vitality.

### 3.1.4 Effects on forest regeneration and growth

Overall, soil compaction negatively affects forest growth (Arvidsson, 2001). Many of the effects discussed in the previous paragraphs, like decreased gas exchange capacity or rooting ability, have an influence on forest regeneration and growth. For instance, water shortages cause the plant to close its stomata, hence hampering photosynthesis. Reduced photosynthesis means a plant can produce less sugars needed for plant growth. Consequentially, plant growth, even forest productivity, can be reduced (Kozłowski, 1999). Negative impacts of soil disturbance mainly affect the younger stages of tree life, but it is important to note that these effects have long term influences on forest stand development.

Germination and growth of young seedlings are hampered by compaction. As already discussed in paragraph 3.1.2 compacted soils are generally more difficult to penetrate than non-compacted soils, which decreases seedling survival chances. However, survival chances differ per species. Seedlings with thicker roots can have more difficulty penetrating compacted soils than seedlings with slimmer roots, which can find their way through small pores more easily (Basset *et al.*, 2005).

An example of the effect of soil compaction on seedling growth was studied by Cambi *et al* (2017). In their study on seedlings of Pedunculate oak (*Quercus robur*) on coarse loamy soils, Cambi *et al* (2017) found that soil compaction decreased seedling growth on several aspects. Compaction decreased the number of growth flushes (-22%), the shoot biomass (-26%), the shoot/root ratio (-10%) and the main root length (-24%). Photosynthetic rates and leaf nitrogen contents were lower as well (-34% and -27% respectively). Main causes of decreased seedling growth were limited access to nutrients and water due to shorter main root lengths.

Effects caused by soil compaction in the seedling stage can be still visible in later stages. Heninger *et al.* (2002) found a difference of 10% in height and 29% in volume in Douglas-fir seedlings planted in and outside skid trails after 10 years, in favour of trees outside ruts. Wert and Thomas (1981) found that, even 32 years after a clear-cut, there were 33% less trees growing within the ruts. Moreover, trees growing in the ruts showed significantly lower volumes than trees growing next to the ruts or on undisturbed soil. Both studies note that current growth rates of adult trees are similar inside and outside ruts. However, due to disadvantages in the past, total volume of trees growing within ruts still lacks behind tree volume of trees growing outside the compacted area.

As mentioned in paragraph 3.1.2 soil compaction can influence hormonal growth regulators in trees. The hormone ABA influences stomata activity and hence controls gas exchange in plants. With soil compaction, water shortage can occur, causing the stomata to close, which hinders gas exchange, and therefore hinders the photosynthesis which produces the sugars needed for plant growth (Tardieu *et al.*, 1992).

Also, forest exploitation with machines can lead to root damages which often causes rot. Borchert *et al.* (2008) describe a study in which all root parts damaged by forestry machines had created rotten spots, which, sooner or later, will enter the tree xylem.

### 3.1.5 Effects on flora and fauna

In compacted and deformed soils, different environmental conditions occur locally than in the surrounding non-damaged forest parts. These different conditions can lead to a change in flora and fauna. The compression and ploughing effects near the ruts may temporarily cause better conditions for ruderal plant species, disturbance indicators like nettles, to settle (Godefroid & Koedam, 2004), while typical forest floor vegetation may disappear near the ruts. Several studies (Buckley, 2003; Ampoorter *et al.*, 2008; Demir *et al.* 2008; Makineci *et al.*, 2008) have shown that soil compaction and deformation can (significantly) change plant species composition and abundance. For instance, in a field study in Flanders Ampoorter *et al.* (2008) found that purple moor-grass (*Molinia caerulea*) and European white birch (*Betula pubescens*) were predominately found on sites with compacted soil, whereas waivy hair grass (*Deschampsia flexuosa*) and alder buckthorn (*Rhamnus frangula*) were predominately found on sites with non-compacted soil. Rowan (*Sorbus aucuparia*), narrow buckler-fern (*Dryopteris carthusiana*), broad buckler-fern (*Dryopteris dilatata*), silver birch (*Betula pendula*) and bramble (*Rubus spp.*) did not show any preference for compacted or non-compacted sites.

Plant species richness on compacted soils is not necessarily lower than non-compacted soils (Buckley, 2003, Ampoorter *et al.*, 2008; Demir *et al.* 2008; Makineci *et al.*, 2008).

Stagnating water in compacted ruts may create (temporal) interesting microhabitats for amphibians and insects. However, no studies on long term effects of soil compaction on forest flora and fauna have not been found in this literature review.

## 3.2 Economic effects

The effects described in paragraph 3.1 indicate that soil compaction and deformation influence tree productivity and vitality. This will influence forest resilience and the volume of harvestable timber and the quality of this timber. However, there is little research on to what extent the effects have an economic impact. Some relevant studies are discussed below.

Stewart (1986) modelled the economic effects of soil compaction in forestry. He investigated the effect on net present value of a harvest plan from changing the skid trail spacing, increasing skid trail spacing to avoid compaction and improve forest productivity. For an extreme scenario of soil compaction, he found that the increase in skid trail spacing resulted in an improvement in net present value. Potvliet (2016) calculated the financial impact of the use of fixed skid tracks for a Scots pine (*Pinus sylvestris*) stand in the Netherlands. For the first generation of Scots pine the use of fixed skid tracks to avoid soil compaction in the rest of the stand did not have an economic effect on the revenues of the stand, because it was assumed that soil compaction did not significantly affect the growth of the remaining stand. However, for the second generation (following after harvesting the original stand) the revenue per hectare increased by 14,3%. This effect was caused by the expected hampered survival and growth of seedlings.

Borchart *et al.* (2008) describe decreases of timber revenue of 60-97 euro per ha in 2007, timber prices decreasing with 20% due to rotting caused by root damage caused by soil damage. For dimensional lumber, revenues decreased with 30-40 euro per cubic meter due to discolorations because of rotting. In this case, 43% of stems was discoloured, resulting in losses of 41-66 euro per ha for dimensional lumber.

### 3.3 Effects on recreational and cultural values

Although, soil compaction will not affect the recreational value of the forest. Deep ruts may contribute to the already negative image of forest exploitation (De Schrijver *et al.*, 2018).

Forests general boast a rich history and are a huge source of cultural heritage, both above and below the soil surface. Forest soils harbour centuries of history and cultural activity, even in the top soil layers (Jansen *et al.*, 2012). Examples are earth banks and ditches that marked borders or kept cattle out of the forest. Also, many ancient hollows, that are the result of the extraction of iron, gravel, stone, loam or sand from the soil, can be found in forests. Dutch forests are very rich in burial mounds and fields of urns from the Bronze Age (2000-800 BC) and the Iron Age (800-12 BC). Medieval transportation routes across Europe are still visible in forests as small ditches caused by cart wheels ((Boosten *et al.*, 2011; Jansen *et al.*, 2012). Remnants of Celtic fields, agricultural field structures that were used from the Late Bronze Age (1100-800 BC) up to the Mid Roman Age (70-270 AD), are also present in many Dutch forests (Kooistra and Maas, 2008).

These historical elements are very vulnerable to disturbance by machines during forestry exploitation. Part of the historical (archaeological) elements are clearly visible in the forest and some of them are even protected by law or by forest certification schemes like FSC and PEFC. However, many elements are not visible, not properly mapped or not even discovered yet and therefore barely protected against damage during forest operations. For example, in the case of burial mounds which are often well known and preserved, the area around the mounds can contain many archaeological traces and remnants which are often not protected (Wispelwey, 2010).



## 4 Recovery after soil compaction and deformation

### 4.1 Natural soil recovery

There are natural mechanisms that help soils to recover partly or completely from compaction and deformation. However, natural recovery in general is a very slow process. The main factors that can contribute to soil recovery are freezing, swelling and biological activity.

Freezing and thawing of the soil surface causes the water in the soil to swell and shrink in the pores. This movement increases the soil pores, which leads to an increase in volume of the pores, hence decreasing soil density (Ampoorter, 2011; De Schrijver *et al.*, 2018). However, little is known on how freezing exactly contributes to soil recovery, which temperatures are needed and how long the freezing period should last.

Clay particles swell when they take up water and shrink again when water is released. Therefore, on clayey soils, moisturizing and drying out of the soil can contribute to soil recovery (Ampoorter, 2011; De Schrijver *et al.*, 2018).

Biological activity, too, enhances soil recovery. Rooting of plants increases pore volume and the connection between the pores. However, in strongly compacted soils, only few plants are able to root. Soil fauna, earthworms living deep in the soil in particular, improve soil structure through their digging activities. However, earth worms too have difficulty to dig through highly compacted soils (Ampoorter, 2011; De Schrijver *et al.*, 2018). Bottinelli *et al.* (2014) even state that earthworms do not play a role in soil recovery in the first few years after compaction, since soil habitat quality has become unsuitable and soil earth worm populations are decreased.

As mentioned before recovery in general is a very slow process. Especially on sandy soils, where only little water can be retained, where there is no clay and only very little biological activity, recovery takes a lot of time. Therefore, on sandy soils with low biological activity, a small increase in bulk density may have large consequences due to this low recovery capacity (Ampoorter *et al.*, 2007). Also, Ebeling *et al.* (2016) found faster recovery on sites with high biological activity and high clay content. Here, recovery took 10-20 years, whereas on sandy soils, after 40 years, the soil was still not fully recovered since gas diffusivity was still significantly reduced in the wheel tracks.

Depending on soil type and level of compaction, soils need 10 to even 100 years to recover (De Schrijver *et al.*, 2018). Ampoorter *et al.* (2010) found that recovery takes at least 20-30 years. Complete recovery of gas exchange and fine root structures under wheel tracks takes even more time (at least 40 years) (Ampoorter, 2010). In deeper layers, soil compaction can still be present even 50-100 years after compaction (Greacen & Sands, 1980 via Ampoorter *et al.*, 2011). Although, natural recover periods can vary greatly, from the studies literature it becomes clear that natural recovery in general takes much longer than the average forest exploitation interval.

## 4.2 Measures to facilitate recovery

Measures that can be taken to facilitate soil recovery are stimulation of biological activity and mechanical enhancement of the soil.

To stimulate biological activity, the soil environment has to become more attractive for earthworms. Especially anecic worms like the *Lumbricus terrestris* are of importance for soil recovery. These vertically and deeply burrowing worms come to the soil surface to feed on fresh litter. On their way back down, their nutrient rich faeces create higher nutrient concentrations deeper into the soil and due to their traffic between top soil and deep down, they greatly enhance better soil aggregation by recreating pore structures with their burrowing (Ampoorter *et al.*, 2011A).

Many earthworm species are susceptible to soil acidification. Tree species composition can influence soil acidity and therefore earthworm presence. Introducing or favouring species that counter the acidification process through their litter, like sycamore (*Acer pseudoplatanus*), aspen (*Populus tremula*), lime (*Tilia spp.*), hornbeam (*Carpinus betulus*), hazel (*Corylus avellana*) or even birch (*Betula spp.*) may help to enhance earthworm populations and thus enhances soil recovery. Planting species that are well adapted to root in dense soils, like alder (*Alnus spp.*) can also help to increase pore volume and enhance the soil environment for earthworms (De Schrijver *et al.*, 2018). Application of high-quality litter (leaves) or liming also helps to enhance the earthworm environment (Ampoorter *et al.*, 2011A).

Meyer *et al.* (2011) describe an experiment where two-year-old common alder (*Alnus glutinosa*) saplings are planted in ruts in order regenerate the upper 30 cm of the compacted soil (fig. 4.1). Common alder is a pioneer species which is well able to grow under wet and low oxygen conditions and hence is an interesting species when striving to facilitate soil regeneration. In their test, Meyer *et al.* (2011) found that without facilitation, after seven years, soil density improved with 3.6% (1.63 g/cm<sup>3</sup>) compared to the initial compaction level after disturbance (1.72 g/cm<sup>3</sup>). In ruts in which saplings were planted, soil density decreased with 5% (1.57 g/cm<sup>3</sup>). When the saplings planted in ruts were provided with compost at the moment of planting, soil density decreased even more: 15% improvement (to 1.45 g/cm<sup>3</sup>) after 7 years compared to initial compaction level after disturbance. Although, the results show an improvement of the soil density. The density after 7 years is still quite high and even above the some of the critical densities for root growth mentioned in table 3.1.



**Figure 4.1**

Ruts planted with two-year-old common alder seedlings to facilitate regeneration (Source: Meyer *et al.*, 2011).

Compared to sites where no regeneration measures were taken, the sites with planted alder saplings contained four to five percent more macro pores (Fig. 4.2). However, compared to the undisturbed soil the level of macro pores on sites where alder was planted was still quite low after seven years. Regeneration of pore structure leads to better air conductivity. By planting alder saplings in ruts and applying compost to facilitate the saplings, air conductivity even reached similar levels as prior to compaction (Fig. 4.3). Hydraulic conductivity regenerated as well. The difference between saplings planted without and with compost was also considerable; the latter saplings grew up to 50% more root mass compared to the former (Fig. 4.4) (Meyer *et al.*, 2011).

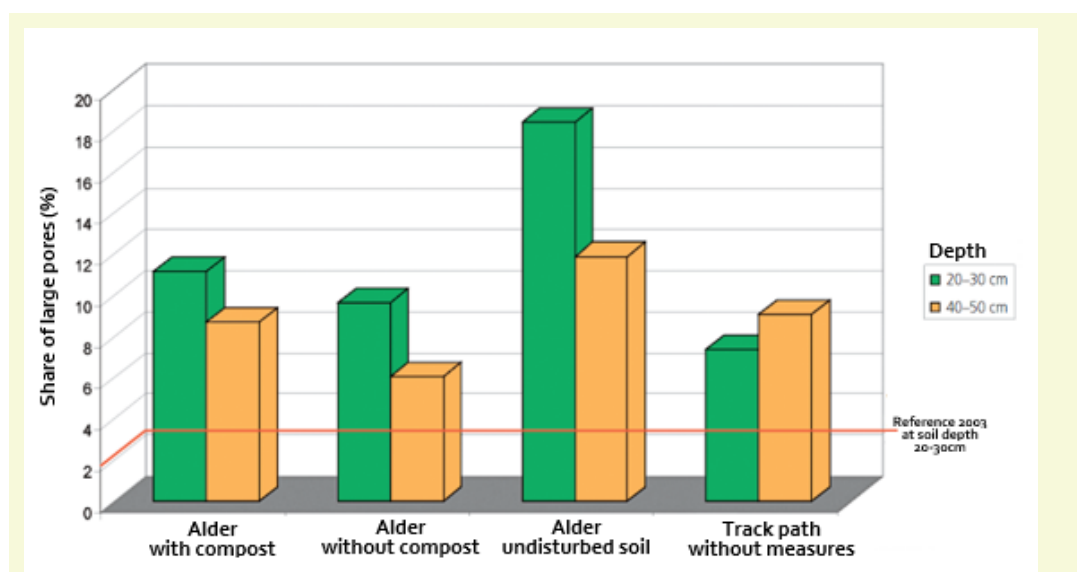

**Figure 4.2**

Presence of large pores in the soil on sites with and without planting of alder saplings after compaction. Source: Meyer *et al.*, 2011).

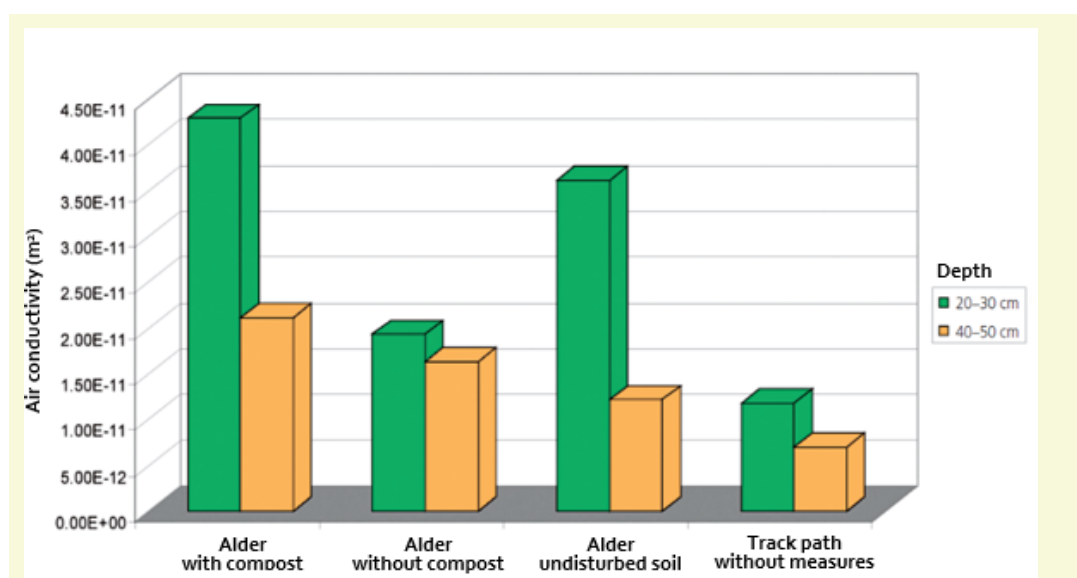

**Figure 4.3**

Differences in air conductivity in the soil on sites with and without planting of alder saplings after compaction. (Source: Meyer *et al.*, 2011).

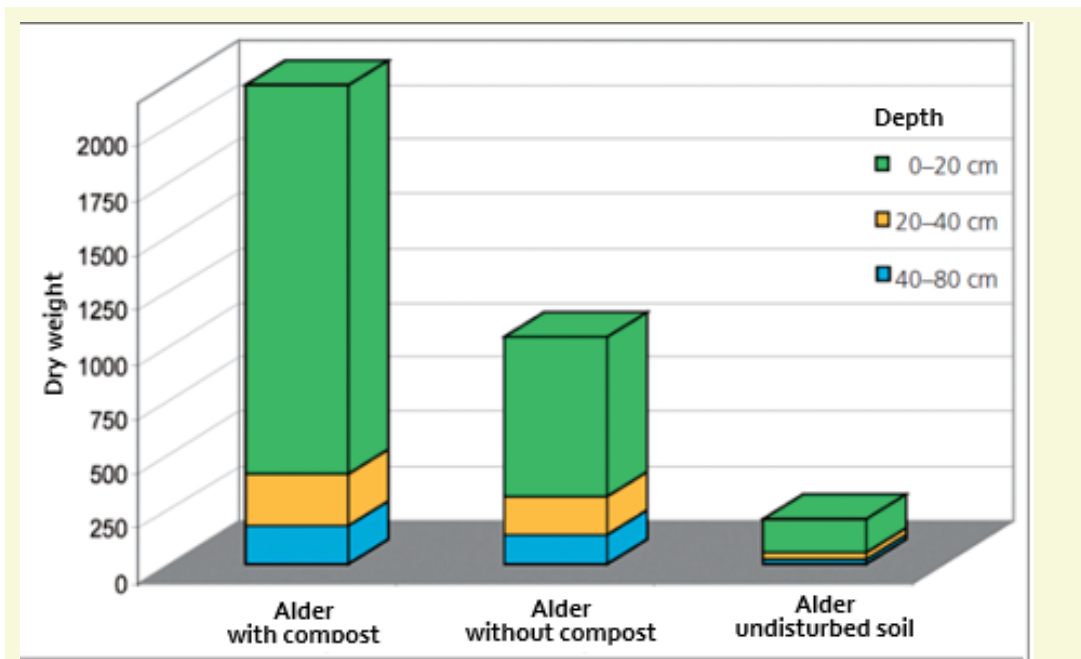

**Figure 4.4**

*Difference in root mass dry weight after seven years for saplings of common alder planted in track paths with and without compost and on undisturbed soil. (Source: Meyer et al., 2011).*

Mechanical routing of the soil, like ploughing, harrowing or milling, can also be done to loosen up the top soil. However, in forests caution advised when applying these measurements, since they can have many negative effects as well. Tree roots and soil organisms can get damaged, soil layers are mixed up, the herbaceous layer will be damaged and increased mineralization increases the risk of leaching of nutrients (Ampoorter, 2011; De Schrijver *et al.*, 2018).



## 5 Forest exploitation and soil compaction and deformation

To prevent or minimise soil compaction and deformation it is important to have an overview of the most important machine characteristics that can influencing soil disturbance (paragraph 5.1) Paragraph 5.2 describes the effect of the frequency of machine movements. Paragraph 5.3 provides guidelines on determining the optimal exploitation conditions for preventing or minimising soil compaction and deformation. Finally, paragraph 5.4 discusses permanent skid roads as an exploitation method for preventing or minimising compaction and deformation.

### 5.1 Machine characteristics

Machines cause minimal disturbance if their contact area and weight are appropriate, so the soil is able to respond elastically, and no visible ruts will appear (Allman *et al.*, 2015). The pressure a forestry machine exerts on the soil depends on the machine's footprint: the weight of the machine per area of contact with the soil surface. Machines with a smaller footprint area, thus a higher soil contact pressure, cause higher degrees of soil compaction. The footprint area is determined by the number of wheels, tyre dimensions, tyre pressure, tyre tread pattern and the use of tracks (Ireland, 2006; Ampoorter *et al.*, 2010A).

If machine weight increases more strongly than the machine's soil contact area, the machine's footprint increases, and with it the machine's impact on the soil. To decrease soil compaction, measures like lower machine weight and increase of the surface area can be taken (Ampoorter, 2011). Several measures concerning chassis design and choice of wheels/tracks can be taken to make the machine's impact on the soil as low as possible.

When describing machine weight recommendations, a combination of machine load and ground contact pressure should be used. This combination is necessary because wheel load alone does not provide any information about the stress level transferred to the soil (Alakukku *et al.*, 2003). However, in this literature research no specific guidelines were found for optimal wheel loads in combination with ground contact pressure.

#### 5.1.1 Calculating machine ground pressure

The ground pressure of a machine is determined by its footprint area, weight distribution and tyre characteristics. These are included in the formula for calculating mean ground pressure as shown in Formula 5.1 (left). With band tracks fitted to the tyres, the formula differs slightly (Formula 5.1 right). The 1.25 multiplication factor is added to consider the area of track between the wheel centres on the bogie (Ireland, 2006).

##### Formula 5.1

Formula's for calculating ground pressure for machines with wheels (left) and machines with tracks (right) (source: Ireland, 2006)

$P = \frac{W}{R \times B}$	$P = \frac{W}{B \times (1.25 \times R + L)}$
P= mean static ground pressure (kg/cm <sup>2</sup> )	P= mean static ground pressure (kg/cm <sup>2</sup> )

W= wheel load (total weight/ nr. of wheels in contact with the ground)	W= wheel load (total weight/ nr. of points of contact with the ground)
R= unloaded tyre radius (cm)	B= track width (cm)
B= tyre width (cm)	R= track wheel radius (cm)
	L= distance between track wheel centres (cm)

### Static vs dynamic soil pressure

Actual soil pressure can be much higher than just the initial static soil pressure (Ampoorter *et al.*, 2010A) Static soil pressure (a measure of soil pressure in kg/cm<sup>2</sup>) can be calculated for a stationary machine by dividing the weight of the machine by the footprint area of the tyres/tracks. The lower the machine weight and the larger the footprint area, the lower the soil pressure, and hence the lower the soil compaction will be (Goris, 2018).

With static soil pressure, it is assumed that pressure is divided equally among the footprint area. However, actual (dynamic) soil pressure can be much higher because dynamical factors are of influence as well. For example, high peaks in pressure are created when shocks or movements occur whilst driving through uneven terrains. The actual soil pressure is very complex and practically unmeasurable during the forest exploitation activities (Goris, 2018).

## 5.1.2 Machine weight

### Machine load

Currently, fully loaded forwarders can easily reach total weights of more than 40 tonnes and harvesters, too, can weigh 15 to over 20 tonnes. Half loaded forwarders exercise less soil pressure but have to drive across twice as often to get all logs out of the forest (Wehner *et al.*, 2010; Frutig & Lüscher, 2015). Compared to half load, skidding with full load causes significantly higher penetration resistance (higher soil density and smaller pore volume). In Frutig and Lüscher's study on skidding with full and half loaded situations, gas exchange and water conductivity decreased slightly for both machines. However, with half load, deeper ruts were created due to the double amount of driving. (Frutig & Lüscher, 2015).

For sand and clay soils, Ampoorter *et al.* (2008) compared the effect of two machines with different weights on the level of soil compaction: a light machine often used for skidding e.g. firewood, weighing 1.5 ton, and a heavy grapple skidder, weighing 11.8 ton. The lighter machine showed significantly less soil compaction effects than the heavy machine on sand and clay soils. For loamy soils, clear compaction effects were found as well, although they were not significant.

The Bayerische Staatsforsten (Forestry service Bavaria, Germany) developed guidelines for maximum wheel load of forest exploitation machines on set skid trails. Wheel loads (load per wheel) of less than 4 ton are mentioned as optimal. Wheel loads of 4 to 4.5 ton are still tolerable, where wheel loads up to 4.9 ton are undesirable (BaySF, 2010). Kremer *et al.* (2012) also note that maximum wheel load of 4-4.5 ton should not be exceeded on compaction sensitive (fine textured) soils. Wheel loads higher than 5 ton are seen as unacceptable because they considerably increase the risk of soil fractures (BaySF, 2010). Table 5.1 summarizes the wheel load ranges found in literature.

**Table 5.1***General wheel load ranges found in literature*

Source	Most optimal wheel load	Less suitable wheel load	Undesirable wheel load
BaySF, 2010	< 4 ton	4-4.5 ton	> 4.5 ton
Matthies, 2009	3 ton	4 ton	
Kremer et al., 2012			Max. 4-4.5 ton

Matthies (2009) studied the employability (number of days that soil conditions were good enough for the machine to be used) of forwarders with varying wheel loads in Germany throughout several years. It turned out that forwarders with a wheel load of 3 tonnes could be employed 93-321 days of the year, whereas forwarders with a wheel load of 4 tonnes could only work 10-185 days. Since employment for at least 150-200 days a year is necessary for the machine to be profitable, for the latter machine, soil conditions too often were not suitable. Hence can be concluded that wheel loads of 4 tonnes or more are only allowable under a small range of optimal conditions and often such wheel loads are too high for the machine to be utilised sustainably.

#### Machine weight modifications

An option to decrease machine mass in harvesters is to reduce/remove the water filled tanks and/or contra weights that are used to stabilize the machine and decrease machine arm length instead to gain better weight distribution (Wehner *et al.*, 2010). However, options for harvesters and crane machines to reduce weight are limited since weight is needed to create stability during operation of the machine (Hauck, 2001; Kietz *et al.*, 2017). When machine stability decreases, crane range decreases and more soil surface has to be used to reach all marked trees.

Pressure exerted by hauling trees from a standstill position causes pressure peaks on top of the basic soil pressure of the stationary operating machine. These peaks can be reduced by changing the coupling point of the hauling element. Kietz *et al.* (2017) found that, for smaller machines, this pressure was about a tenth the size of the pressure exerted by large harvesters of forwarders. Especially for longer hauling distances with longer machine arms, soil pressure of the stationary machine increases tremendously.

### 5.1.3 Machine track types

Looking at undercarriage components, there are generally three types: tyres, tracked tyres and continuous tracks. Machines with tyres can reach relatively high driving speeds. When adjusting tyre pressure, tyre machines can adapt to terrain and quell bumps and vibration (Goris, 2018).

#### Tyres

In general, the use of wider tyres and more tyres in general decreases the risk of soil compaction since pressure is divided across a wider tyre surface and wheel load of individual wheel is lower. Reduction of tyre pressure, too, can decrease the amount of soil damage. Especially for old, undisturbed soils, but also for soils recovering from compaction, tyre pressure should be as minimum as possible. However, too low tyre pressures could cause excessive damage to the

tyres, diminishing their lifespan. Automated tyre pressure regulation systems could facilitate optimal tyre pressure throughout exploitation activities. (Wehner *et al.*, 2010)

Increasing the number of wheels of a machine (creating a so-called tandem axle) leads to a lower wheel load and therefore to a lower ground pressure. However, there is a trade-off, which is called the 'multi-pass effect'. With more wheels in a row, the average ground contact pressure per wheel is lower, but the number of wheels passing the same path is higher as well. This might increase the risk of subsoil compaction. To prevent this multi-pass effect, other solutions like wider tyres and dual wheel arrangements (wheels next to each other instead of behind each other) might be more efficient (Alakukku *et al.*, 2003). Ireland (2006) states that, instead of two single rows of wheels, double wheels can be used to increase flotation by increasing the machine's footprint area. However, this also increases machine width, which could have operational implications for site management.

Weise (2008) distinguished two main types of tyre tread patterns (fig. 5.1): traction profile and implement-traction profile. For classic traction profile tyres, the tread pattern consists of big sharp edged, protruding elements on the sides ('shoulders') which enable for proper grip on the soil and high traction. However, these tyres also inevitably cause ground scarification. With the implement-traction profile, the tread profile is flatter, with less room in-between tread pattern elements and less protruding tyre shoulders. Soil grip of these tyres is less deep and aggressive than traction profile tyres, making them more suitable for activities on soils susceptible to ground scarification.



**Figure 5.1**

*Two types of tread patterns. Left: traction profile. Right: implement-traction profile. (Source: Weise, 2008).*

Low-profile wide tyres are most optimal in terms of tyre width and diameter. With high soil moisture content, application of Bogie tracks on front and rear tyres has proven useful for preventing ground damage because they double the footprint and hence reduce soil pressure. With these tracks, it suffices to put tracks on the front vehicle and wide tyres on the rear vehicle

(BaySF, 2010). Guidelines of the state forest company of Saxony, Germany, prescribe for forwarders a minimum tyre width of 600 to preferably 700 mm (Staatsbetrieb Sachsenforst, 2006).

Broader tyres have a smaller footprint, since wheel load can be spread out over a larger soil surface area. However, Schack-Kirchner (2010) found that in terms of oxygen availability for root growth, broader tyres cause a bigger difficulty for root growth since sideways expansion of compaction is larger in comparison to smaller tyres. Also, soil oxygen concentration is affected over a wider area compared to soil pressure by smaller tyres (fig 5.2).

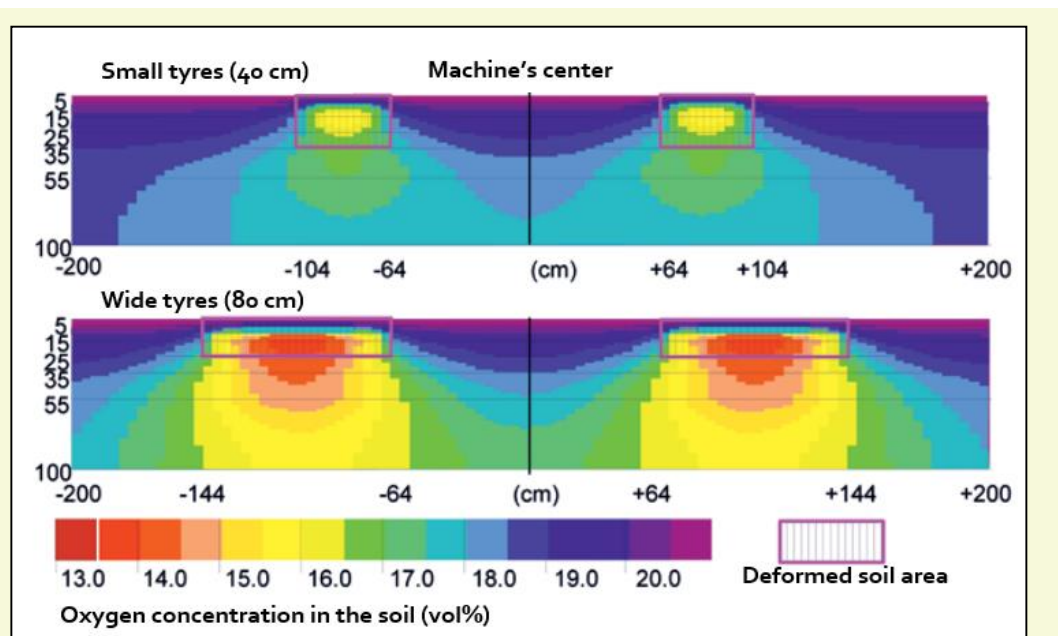

**Figure 5.2**

*Simulation of the effect of track width on oxygen concentration in the soil, essential for root respiration. The more sideways expansion, the larger the area where root respiration is affected due to soil compaction. Source: Schack-Kirchner (2010)*

Changes in tyre pressure can greatly influence soil pressure. Reducing tyre pressure considerably increases the footprint area of the tyres. Changing tyre pressure can contribute up to 35% to optimal soil conservation conditions (table 5.2). For example: reducing tyre pressure of a fully loaded Timberjack 810B from 4.5 bar to 1.5 bar can decrease soil pressure with about 29% (Kremer *et al.*, 2012).

Alakukku *et al.* (2003) prescribe that tyre inflation pressure should always be as low as allowable in the prevailing circumstances of tyre loading capacity, velocity and traction. Optimizing tyre inflation pressure could potentially decrease contact soil pressure with up to 25%, simultaneously increasing traction and decreasing vibration loads in a similar magnitude (Hauck, 2001).

**Table 5.2**

*Soil conservation factors that can influence the level of soil compaction of forestry machines (Source: Kremer et al., 2012)*

Soil conservation factor	Optimize	Effect	Max. share in conservation measures
Number of wheels	Increase	Lower wheel load	55%
Tyre pressure	Decrease	Bigger footprint area	35%
Tyre width	Increase	Better division of wheel pressure	10%

Shearing forces are caused by propulsion and traction of a machine. The more gradual and variable propulsion of a machine takes place, the less damage the machine will cause to the soil. Tyre undercarriages that can drive all tyres at once, can divide the shearing forces among all tyres, hence dividing the force more evenly across the soil.

The level of traction of a machine is determined by its built, weight, driving and propulsion. Machines that can drive more of their tyres can create a higher level of traction. Under slippery circumstances, chains or bogie tracks (steel track chains) can be put around the tyres to increase traction (Goris, 2018).

#### Bandtracks

Bandtracks are fit around the machine's tyres to provide the machine with more contact surface with the soil, which decreases the amount of soil compaction (fig. 5.3).

Bandtracks increase traction and flotation<sup>3</sup> but they also add significantly to the machine's overall weight and increase rolling resistance. Each track may weigh at least a tonne. However, the effect of increasing the machine's footprint and hence reducing ground pressure compensates for the added weight (Ireland, 2006).

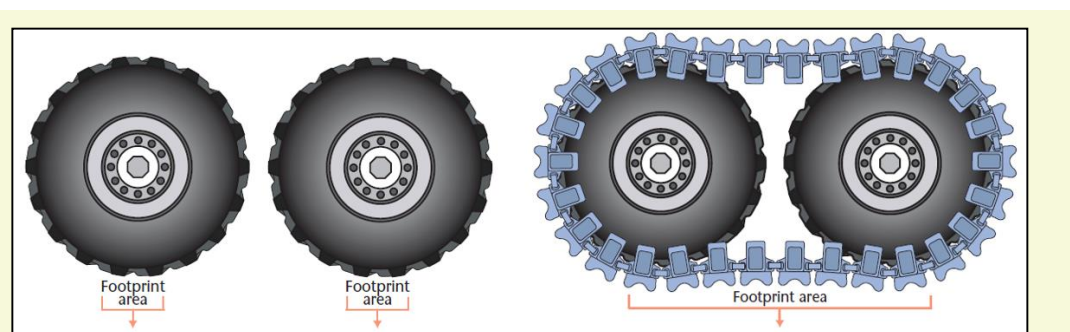
**Figure 5.3**

*Footprint area of two single wheels (left) and wheels with band track (right). (Source: Ireland, 2006.)*

Ireland (2006) describes two main types of band track design: band tracks with a side link and band tracks with side paws (fig. 5.4). With side link tracks, the plates are connected with forged links at the end of each plate. These tracks are lighter weighted than side paw tracks, but link

<sup>3</sup> Flotation: the machine's ability to stay on the soil surface (especially of importance with soft ground)

ends can cause more disturbance during movement. Therefore, side link tracks are best suited for machines that carry out minimal movement between sites.

In tracks with side paws, the tracks are substantially wider than the tyre, which improves flotation. Side paws are positioned close to the tyre to keep firm contact with the tyre's side wall during exploitation activities. The side paws also provide support during turning and traveling on side slopes, keeping the tracks in place when exposed to lateral forces. In addition, they also reduce ground scuffing and rolling resistance (Ireland, 2006).

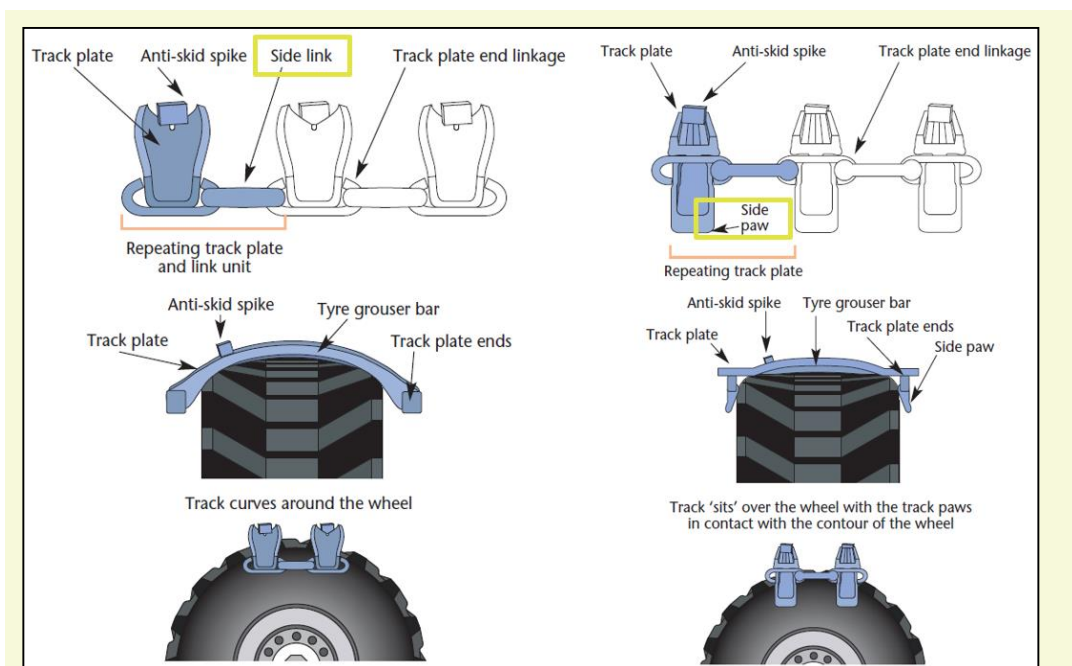

**Figure 5.4**

*Two types of band tracks; with side links (left) and side paws (right). (Source: Ireland, 2006)*

Plate spacing also influences the track's soil impact. The longer the links between plates and the more distance between the plates, the more aggressive the track and the more soil damage it can cause. With shorter links the track surface area is larger, increasing track flotation and surface contact with the tyre, which prevents slippage during movements. However, the shorter the links, the higher the weight and cost since more plates are needed to make up the track. (Ireland, 2006)

Alakukku *et al.* (2003) also note a difference in track material between steel tracks and rubber tracks, with steel tracks compacting the soil less than rubber tracks. A rubber track's edges are more flexible, concentrating stress below the jockey wheels at the centre of the track, hence creating a more uneven distribution of machine forces than is the case with the more rigid steel tracks.

Heubaum (2015) compared the relation between soil compaction and shear strength for different types of tracks (fig. 5.5). For similar machine movements, with decreasing shear strength, the effect of no tracks increases considerably compared to the different track types.

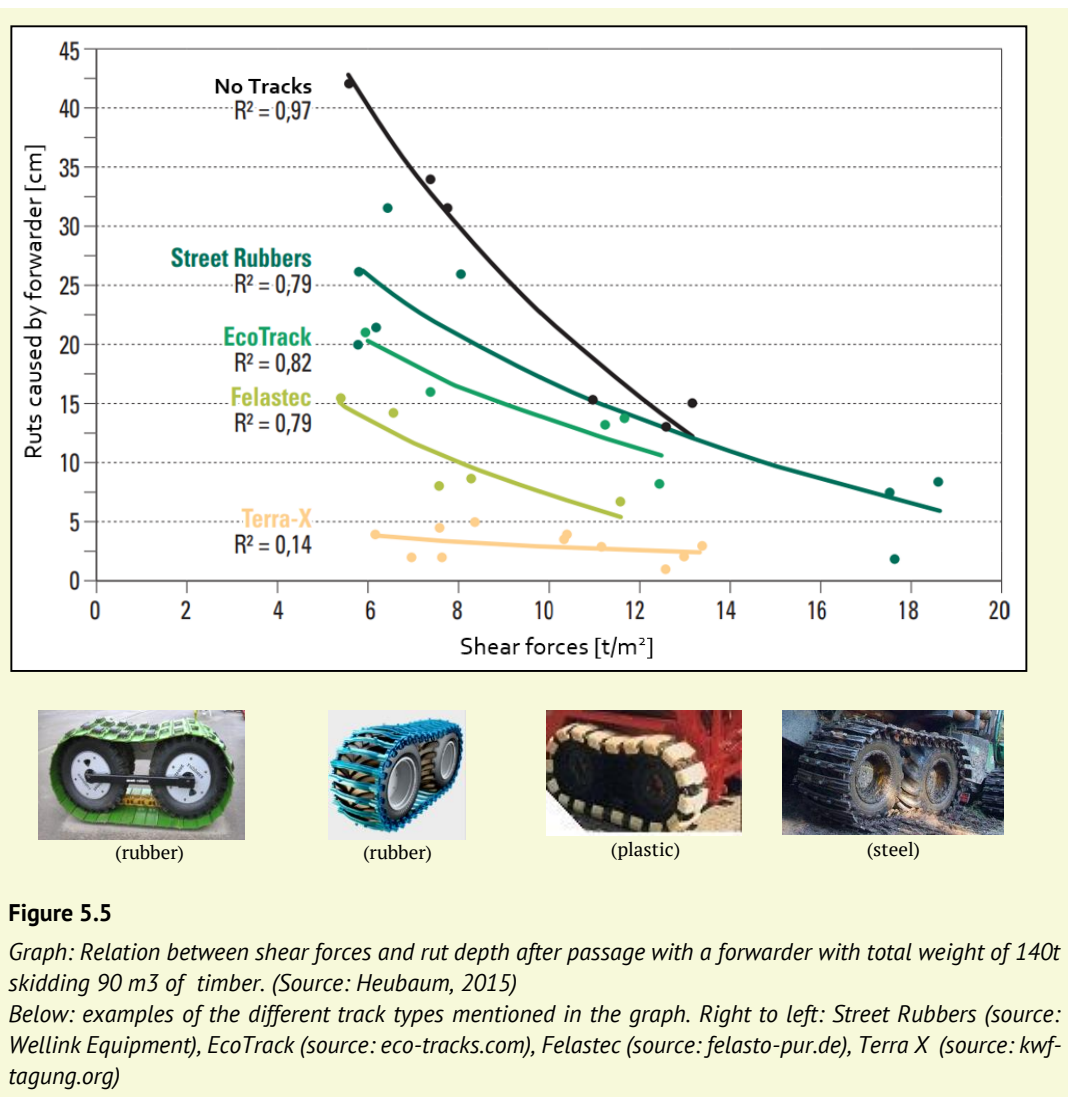

Kremer & Schardt (2014) compared the soil damage effects of low-pressure profile tyres<sup>4</sup> to two types of Bogie tracks, the universal “Eco-Track”<sup>5</sup> and the soft track “Eco Baltic”<sup>6</sup> on an eight-wheel forwarder (Dasser TRS 10.8). Soil pore compaction under the bare tyres was 59%, whereas for the Bogie tracks, compaction was 39-40%. The tracks thus cause less compaction than bare tyres.

Although band tracks in general have lower soil damage than tyres, in terms of instant tree damage, low pressure profile tyres cause less damage than both Bogie track types. Kremer et al. (2003) developed a classification system to assess tree damage after exploitation (see textbox below). The tyres mainly caused rind damage (75% of damage in test was class 1 or 2). The Bogie track types, however, caused much more wood damage (42 and 48% of damage in class 3-5). (Kremer & Schardt, 2014).

<sup>4</sup> type Nokian 700/45-22,5 16 PR. TRS LS-2, see <https://www.nokianheavytyres.com/tyres/tyre/nokian-forest-king-trs-1-2/>

<sup>5</sup> <http://www.eco-tracks.com/de/produkte/eco-tracks/vorwaerts/eco-track>

<sup>6</sup> <http://www.eco-tracks.com/de/produkte/eco-tracks/aufwaerts/baltic>



#### Classification of tree damage characteristics

- 1 Rind damage: rind squashed (resin leaking)
- 2 Rind damage: rind taken off, wood exposed; detachment of rind without damage to wood fibre
- 3 Wood damage: wood exposed, squashed
- 4 Wood damage: wood exposed, squashed and shredded
- 5 Wood damage: roots broken and/or ripped off

Allman *et al.* (2015) measured dry bulk density to indicate compaction effects of various machine chassis types. To eliminate bias from variation in soil moisture, dried soil samples were analysed. The results are shown in table 5.3. In this study, tracked chassis proved to have the least effect on soil compaction (once the effect of varying soil moisture content is ruled out). In general, their results showed that the wheeled chassis caused 25% more soil compaction compared to machines with tracked chassis.

**Table 5.3**

*Comparison of soil compaction effects of different types of machine chassis. (Source: Allman et al., 2015)*

Machine technology	Chassis type	Bulk density after drying (g cm <sup>-1</sup> )	Average increase in bulk density in skid trails compared to undisturbed stand (g cm <sup>-1</sup> )	Average % increase bulk density in skid trail compared to undisturbed stand
CTL (3 machines)	Wheeled	1.25-1.36	0.35	35.4%
CTL (2 machines)	Wheeled/tracked	1.02-1.06	0.21	25.3%
Skidder (3 machines)	Wheeled	1.25-1.36	0.30	30.3%
<b>Average</b>			<b>0.30</b>	<b>32%</b>

#### Continuous/ caterpillar tracks

Uhl *et al.* (2003) state that machines with caterpillar tracks are unequivocally more soil friendly in terms of compaction. Caterpillar track design offers a much bigger soil contact area and hence a much larger machine footprint compared to wheels or band tracks, especially on even terrain, decreasing soil compaction compared to different machines with similar machine weight and load.

However, when measuring disturbance in terms of root damage, caterpillar tracks cause more severe damage than wheeled machines (although the number of damages is similar). Damage surfaces can be up to four times larger with caterpillar tracks compared to wheeled machines (Uhl *et al.*, 2003; Borchert *et al.*, 2008). When assessing suitability of different machine types, it is important to determine which factors (soil compaction, root protection) are most crucial to consider. Uhl *et al.* (2003) advise in young and middle-aged forest stands to choose wheeled machines due to their lower damage to tree roots and stems (provided that measures are considered like low tyre pressure and high nr. of tyres to reduce wheel load) and to choose

caterpillar tracked machined in older forest stands, to consider soil damage prevention, since in older forest stands effects of root damage will lead to less value losses than earlier stages. On the other hand, Burchart *et al.* (2008) argue to not let the risk of root damage be a decisive criterion for machine choice since root damage will occur both with wheeled machines and caterpillar tracks.

On sites with slopes over 30%, caterpillar tracked machines are advised on all forest sites because these machines have better slipping control than wheeled machines, affecting both soil and root/stem disturbance less than with wheeled machines. (Uhl *et al.*, 2003)

Recently, in a European project led by the Norwegian Institute of Bioeconomy Research (NIBIO) a new type of caterpillar tracked forwarder was developed, called the OnTrack Forwarder (fig 5.6)). The OnTrack Forwarder is created using a Ponse Buffalo forwarder and replacing its four wheels on each side with rubber caterpillar tracks. Even though, due to its size, it is more suitable for Scandinavian forest proportions in its current form. The machine has a turning circle of 20,1 m. , the OnTrack Forwarder is a promising development in terms of soil preservation. Weighing 29 tonnes, it is 8 tonnes heavier than the regular eight-wheeled original Ponse Buffalo forwarder. However, due to its large footprint (front 3.3 m<sup>2</sup>, rear 5 m<sup>5</sup>), a fully loaded OnTrack Forwarder (14t load) has a soil pressure of 281 g cm<sup>-2</sup>, which is even less than an empty original eight wheeled Ponse Buffalo forwarder. (Hartkopf, 2018)



**Figure 5.6**

*Caterpillar tracks on the newly developed Ponsse OnTrack Forwarder. (Source: KWF)*

#### 5.1.4 Slipping control

Slipping is the main cause for the creation of ruts. Maximum traction is reached between slipping levels of 40-80%, so many machine drivers strive to get the maximum out of their traction capacities. Slipping control systems could be helpful to gain maximum traction with minimum creation of ruts. However, such systems are not yet commonly available and could be very costly. Easier methods to increase traction are options like wheel chains or Bogie tyres (Wehner *et al.*, 2010). Both with wheels and tracks, aligning the drive torque as optimal as possible with the tyres or tracks can prevent slipping when wheels turn and hence can contribute to preventing soil deformation (Hauck, 2001).

### 5.1.5 Machine velocity

The velocity with which a machine passes the soil also affects the amount of stress exercised on the soil. With higher velocity, the duration of loading on the soil is reduced. Alakukku *et al.* (2003) describe a study in which the effects of velocity on the maximum soil stress below a wheel centre on sandy loamy soil for two different wheel loads were measured. An increase in velocity from 2 km/h to 10 km/h decreased stress at 30 cm depth below the wheel centre. It seems that, with increasing velocity, the stress transmitted to upper subsoil layers reduces. An effect which, according to Alakukku *et al.* (2003) can probably be attributed to the water conductivity characteristics of a soil.

## 5.2 Frequency of machine movements

Most soil compaction takes place during the first machine passing (Brais and Camiré, 1998; Ampoorter *et al.*, 2007; Ampoorter, 2011; Frutig & Lüscher, 2015; De Schrijver *et al.*, 2018). However, compaction effects will keep occurring as long as machine forces upon the soil are larger than soil strength (Ampoorter, 2011).

Allman *et al.* (2015) indicate that maximum soil compaction already occurs at minimum surface soil loading and minimum number of passages, even when wide and low-pressure tyres are used. According to Brais and Camiré (1998) the relation between the number of machine-passes and the intensity of soil compaction can be described logarithmically; The first few passes have a high impact on soil density, which decreases with increasing soil density levels until the soil is decreased to such a level that machine forces have no further impact in terms of compaction. Ulrich *et al.* (2003) also state that, during the first up to the third passage severe soil compaction occurs and, only after the fifth up to the tenth passage, the soil is so compacted that more passages results in only minimal extra increases in bulk density. (Brais and Camiré, 1998; Ulrich *et al.*, 2003; Ampoorter *et al.*, 2010A)

An example is given by Lüscher *et al.* (2005). Lüscher *et al.* compared the penetration resistance of a single-used skid trail and a skid trail used multiple times with the penetration resistance of a reference situation where no forestry machine had compressed the soil. On the multiple used trail, penetration resistance had increased in the first 75 cm of the soil. However, the single-used trail (which was made under favourable soil moisture conditions) already showed an increased penetration resistance in the first 55 cm of the soil. This study shows that, although compaction is higher after more machine passes, but the majority of compaction occurs at the first time of passing.

Frequency of disturbance plays a more important role for heavier machines. Ampoorter *et al.* (2010) note that heavier machines have a higher cumulative impact with every skidding cycle than lighter machines. For lighter machines, the difference with the compaction effect after the first skidding cycle was negligible, but for heavier machines compaction kept increasing during the first 5 cycles.

## 5.3 Determining optimal exploitation conditions

To prevent soil compaction and deformation it is important to choose the optimal exploitation conditions considering forest soil condition (texture, moisture etc) and weather conditions (paragraph 2.2). On fine to medium textured soils (pore volume mainly >50  $\mu\text{m}$ , e.g. loam or clay soils), forest exploitation should be carried out only under lowest possible soil moisture conditions, preferably dry soils, to prevent soil compaction as much as possible (Ampoorter,

2011). On coarsely textured soils, like sand and loamy sand, forest exploitation should be carried out in intermediate or wet conditions (see table 2.2, paragraph 2.2).

Two examples of decision support systems in determining the optimal exploitation conditions are described below.

Grüll (2011; 2013) describes a forest stand focused decision model, developed to determine optimal soil-friendly forest exploitation methods and conditions based on technical driveability of the soil and ecological forest site (production) values. The model classifies suitability of different forest exploitation methods with a diagram model in which ecological classifications and site technical exploitation classifications are used to determine forest exploitation possibilities under certain conditions.

First a forest site classification is exercised in the form of a 5x5 matrix (called a forest technical 'technogram' for site classification), where on the one axis 5 soil value classes (in terms of production value) and on the other axis 5 driveability classes (in terms of soil moisture) are distinguished. The soil value classes are translated into a maximum allowable percentage of driving on the forest site, which then is translated into distance between rut paths (fig 5.7).

**Table 5.4**

*Forest site technogram for classification of forest site conditions based on production value and technical driveability. (Source: Grüll 2011; 2013)*

Soil fertility classification (Production value)					
Class	P1	P2	P3	P4	P5
Fertility	very minimal	minimal	medium	high	very high
Max. % driving on site	> 20%	20%	10%	< 7%	0%
Distance between rut paths	< 20m	20m	40m	60m	No rut paths, cable skidding
Soil moisture classification (Technical driveability)					
Class	T1	T2	T3	T4	T5
Driveability	Passable	Restrictedly passable	Strongly restricted passable	Barely passable	Not passable
Soil moisture content	Dry- moderately moist	moderately moist	Moist	Wet	Marshy
Weather type			Dry	Intermediate	Rain

Next, the technogram's units are coloured in terms of suitability for forest exploitation. Here, current weather conditions are also considered, representing three drivability classes. It is only for these classes that the technogram's units are coloured (fig 5.7).

Red units mean that the corresponding combination of soil value and driveability class is unsuitable for forest machines. Yellow units show the range of conditions where forest machines can be used properly, and application of forest machines is legally allowed. Green units show the range of forest conditions that conform PEFC criteria set for sustainable forest exploitation with machines.

Orange units show the range of forest conditions in which special measures have to be taken to conserve high ecological soil values (higher classes of soil value classification). Green/orange units mean that, with special measures, forest exploitation can be exercised conform PEFC criteria.

In addition to the technogram, for different forest exploitation methods, similar sized diagrams can be produced in which their applicability under certain forest conditions is shown. This diagram can be put on top of the technogram to find the best possible circumstances to exercise forest exploitation with certain forest exploitation techniques. An example from Gröll (2013) is given in figure 5.7.

P5					
P4					
P3	—	★	+		
P2					
P1					
	T1	T2	T3	T4	T5

**Figure 5.7**

*A forest technical technogram (P and T values: see table 5.4) combined with a similar sized diagram on the possibilities for a certain forest exploitation method shows under which circumstances forest exploitation can best be exercised. In this example: options for exploitation with harvester and forwarder (both with tracks), assisted by manual felling. – means a bit suitable, + means suitable, \* means very suitable. The other units in the diagram are unsuitable. Based on the method of Gröll (2013).*

ProFor+ is an information system developed by the Technical University of Munich. The system contains a database with soil mapping units and machine data. For every soil mapping unit, a maximum soil moisture content level at which machine forestry activities are still possible is given (Kaufmann and Lüscher, 2007). By doing driving tests with a forwarder with varying loads on soil patches with different, preconfigured soil moisture contents, thresholds for critical soil moisture contents were developed. These thresholds are based on several ecological and structural soil parameters. In addition, the footprint area of 15 typical forest tyre types was investigated by measuring their footprint area on a hard surface, with varying inflation pressures and wheel loads. These measurements make it possible to predict the static contact pressure of forest machines (Ziesak, 2004). Evaluations proved that the system's predictions were correct, and practicability and usability of the system are high.

## 5.4 Permanent skid roads

Permanent skid roads are treeless zones of about 4 to 5 m wide, present throughout the forest with a regular interval between roads, which are determined as the only forest soil area where machines are allowed to drive during forest exploitation. These set roads are hence the only area of forest that is being disturbed by machines during thinning or end felling of the forest stand. Soil damage is concentrated on these roads, the remaining forest soil is preserved from soil disturbance by heavy machines. In addition, the straight and obstruction free roads can be used more efficiently compared to exploitation without set skid trails and the permanent skid road design makes planning an exploitation structure more straightforward. (Ampoorter, 2011; Goris, 2018)

Distance between skid roads should be at least 20m, preferably more in more vulnerable forest stands. In general, modern forestry machine arms have a range of almost 10m. Their operating range, the area in-between skid roads that machines can exploit efficiently, therefore is almost 20m (Frutig *et al.*, 2016; Goris, 2018). Skid roads of 4m wide at a distance of 20 meter means that at least 20% of the forest stand is being driven by forestry machines. This percentage can be decreased by putting down skid roads at a further distance from each other. Trees outside the range of the harvester can be felled towards the harvester manually, getting the stem within range of the harvester's machine arm. In addition, machines should as much as possible be able to drive in one straight line without turning around, in order to prevent soil damage to the sides of the roads.

Other options are, for example, forwarding trees using a cable winch or a horse. When using these kind of methods, even wider distances between skid roads can be applied. However, there is a trade-off in using wider distances; the skid road is used for exploitation of an area twice the size compared to skid roads on 20m and are therefore more susceptible to soil damage. On the other hand, a larger area of undisturbed forest soil is maintained as well. (Goris, 2018)

It is important to consider the trade-off between distance of skid roads and timber production. Narrower spacing of skid roads may lead to reduced volume and value production due to soil compaction in the forest stand. However, wider spacing will result in higher harvesting costs. Frutig *et al.* (2016) found that, on the long run, it pays off to use a wider spacing (optimal: 30-50m) since losses due to reduced growth and a lower amount of valuable timber are of considerable importance when calculated over the whole rotation period.

Brushwood mats (made of branches from felled trees) can have a protective effect on skid trails and help decrease the effects of heavy machinery on the forest soil. Kremer *et al.* (2005) found in their experiment that no big soil structure changes occurred on skid trails on which brushwood mats were applied. With a brushwood mat on the skid trails, machine weight is spread over a larger contact area than the machines footprint, causing the exerted soil contact pressure to decline. This method does, however, require the logs to be carried out instead of dragged out of the forest, so that the brush mat stays intact. (Ampoorter *et al.*, 2007). However, it can be discussed whether brushwood mats provide enough protection in all situations. Another consequence to consider is the displacement of nutrients in the forest stand because all organic matter normally left behind throughout the forest stand is now concentrated on the skid trails.

## 6 Conclusions and recommendations

### 6.1 Conclusions

Soil compaction and deformation occur during forest exploitation with heavy machinery due to complex interactions of soil pressure, shearing forces and vibrations into the soil. These effects do not only take place right underneath the machine but can also influence the soil up to 0.75 meter sideways of the wheels. Soil compaction does not only occur at the actual moment of machine traffic. Also, one to two years after machine traffic further soil compaction can occur. In general, the majority of the compaction happens during the first machine passing. Subsequent machine passing often causes less (additional) compaction.

Soil susceptibility to compaction is mainly defined by:

- Soil structure and moisture content of the soil;
- The applied machine (weight/ground pressure, track types, velocity etc) in combination with the exploitation method.

Soil compaction (and to a lesser extent soil deformation) can have several effects on the forest ecosystem. The most important effects are:

- hampering gas exchange in de soil and the availability of water and nutrients;
- hampering tree root growth and rooting ability;
- disturbing or altering soil biodiversity (i.e. earthworms, mites and springtails, mycorrhizae);
- hampering the germination of seeds and the development of seedlings;
- altering the composition of the herb layer.

Partly due to the abovementioned effects soil compaction negatively affects regeneration and forest growth. Negative impacts mainly affect the younger stages of tree life, but it is important to note that these effects have long term influences on forest stand development as a whole. Although data are scarce, some studies indicate that the effect of soil compaction on tree productivity and vitality and thus on the volume and quality of harvestable timber, also can have a considerable economic impact.

Natural mechanisms like freezing, swelling and biological activity can help soils to recover partly or completely from compaction and deformation. However, natural recovery in general is a very slow process taking minimal 10 years to several decades.

To prevent soil compaction and deformation it is important to choose the optimal exploitation conditions considering forest soil condition (texture, moisture etc) and weather conditions. In general., forest exploitation can best be done under dry soil circumstances on loam and clay soils and under medium to wet circumstances on sandy soils. Exact guidelines on maximum allowable soil pressure for forestry machines are still lacking. Moreover, there are many machine characteristics that influence the (level of) soil disturbance. This makes it difficult to give detailed guidelines for choosing the optimal machine and/or exploitation method under several circumstances.

## 6.2 Recommendations

This literature review presents many data on the occurrence and impact of soil compaction and deformation in forests. However, research data from the Netherlands are lacking or at least scarce. Therefore, it is recommended to set up a research network of forest managers in cooperation with research institutes to collect data in forest stands in the Netherlands. Forest reserves could be used as reference plots to collect data on undisturbed stands.

As mentioned above exact guidelines on maximum allowable soil pressure for forestry machines are still lacking. In this study we found some data. However, within the scope and time of this study it was not possible to collect enough data to compile a dataset for a thorough analysis. It could be worthwhile to carry out a specific literature review focussing on this aspect.

In this report we described two examples of German decision support systems for determining the optimal exploitation conditions. We recommended to develop a specific decision support system for the Dutch situation, including both site and machine characteristics



## 7 References

- Alakukku, L., P. Weisskopf, W.C.T. Chamen, F.G.J. Tijink, J.P. van der Linden, S. Pires, C. Sommer, G. Spoor. Prevention strategies for field traffic-induced subsoil compaction: a review. Part 1. Machine/soil interactions. *Soil & Tillage Research*. 73 (1-2): 145-160.
- Allman, M., M. Jankovský, V. Messingerová, Z. Allmanová, M. Ferenčík. 2015. Soil compaction of various Central European forest soils caused by traffic of forestry machines with various chassis. *Forest Systems*. 24 (3): 1-10.
- Ampoorter, E., R. Goris, W.M. Cornelis, K. Verheyen. 2007. Impact of mechanized logging on compaction status of sandy forest soils. *Forest Ecology and Management*. 241 (1-3): 162 – 174.
- Ampoorter, E., L. van Nevel, B. de Vos, R. Goris, K. Verheyen. 2008. *Validatie en optimalisatie bosvriendelijke houtexploitatie in Vlaanderen, Eindrapport*. In opdracht van Ministerie van de Vlaamse Gemeenschap – Agentschap voor Natuur en Bos, uitgevoerd door Universiteit Gent – Labo voor Bosbouw, Instituut voor Natuur- en Bosonderzoek, Inverde.
- Ampoorter, E., R. Goris, K. Verheyen. 2010. Maatregelen bij houtoogst. In: J. den Ouden, B. Muys, F. Mohren, K. Verheyen (Red.). 2010. *Bosecologie en Bosbeheer*. Den Haag, Acco Leuven.
- Ampoorter, E., L. van Nevel, B. de Vos, M. Hermy, K. Verheyen. 2010A. Assessing the effects of initial soil characteristics, machine mass and traffic intensity on forest soil compaction. *Forest ecology and management*. 260 (10): 1664-1676.
- Ampoorter, E. 2011. Bodemverdichting door gemechaniseerde houtoogst: gevolgen voor het bosecosysteem. *Bosrevue*. 9 (36): 1-4.
- Ampoorter, E., A. De Schrijver, P. De Frenne, M. Hermy, K. Verheyen. 2011A. Experimental assessment of ecological restoration options for compacted forest soils. *Ecological Engineering*. 37 (11): 1734-1746.
- Ampoorter, E. 2011B. Soil compaction due to mechanized forest harvesting: quantification of ecosystem effects and exploration of recovery potential. Ghent, Ghent University.
- Arnup, R.W. 1999. *The extent, effect and management of forestry-related soil disturbance, with reference to implications for the Clay Belt: a literature review*. South Porcupine (Ontario), Northeast Science & Technology.
- Arocena, J.M. 1999. Cations in solution from forest soils subjected to forest floor removal and compaction treatments. *Forest Ecology and Management*. 133 (2000): 71-80.
- Arshad M.A., G.M. Coen. 1992. Characterization of soil quality: physical and chemical criteria. *American Journal for Alternative Agriculture*. 7 (1-2): 25-31.
- Arshad M.A., B. Lowery, B. Grossman. 1996. Physical tests for monitoring soil quality. *Soil Science Society of America*. (49): 123- 143.

- Arvidsson, J. 2001. Subsoil compaction caused by heavy sugarbeet harvesters in southern Sweden I. Soil physical properties and crop yield in six field experiments. *Soil and Tillage Research*. 60 (1-2): 79-89.
- Aust, W. M., J.A. Burger, E.A. Carter, D.P. Preston, S.C. Patterson. 1998. Visually determined soil disturbance classes used as indices of forest harvesting disturbance. *Southern Journal of Applied Forestry*. 245-250.
- Bassett, I.E., R.C. Simcock, N.D. Mitchell. 2005. Consequences of soil compaction for seedling establishment: implication for natural regeneration and restoration. *Austral Ecology*. 30 (8): 827- 833.
- BaySF. 2010. *Bodenschutz bei den Bayerischen Staatsforsten*. Regensburg, Bayerischen Staatsforsten AöR.
- Boosten, M., P. Jansen, M. van Benthem, B. Maes. 2011. *Boswallen. Handreikingen voor het beheer*. Wageningen, Stichting Probos.
- Borchert, H. M. Blaschke, M. Metan. 2008. Wurzelverletzungen unter Raupe und Rad. Trotz schwerer Wurzelverletzungen bei Raupenfahrwerken schneidenden Raupenfahrzeuge in Vergleich zu Radmaschinen nicht schlechter ab. *LWF Aktuell*. (67): 16-18.
- Brais, S., C. Camiré. 1998. Soil compaction induced by careful logging in the claybelt region of northwestern Quebec (Canada). *Canadian Journal of Soil Science*. 78 (1): 197-206.
- Buchar J, P. Holčíková, K. Rejšek, 2011. Compaction of the top soil horizons of forest soils and the dynamics of saturated hydraulic conductivity in soils compacted by forestry machines. In: Skoupý, A. 2011. *Multikriteriální hodnocení technologií pro soustředování dříví*. Kostelec nad Černými lesy, Lesnická Práce.
- Buckley, D.S., Crow, T.R., Nauertz, E.A., Schulz, K.E. 2003. Influence of skid trails and haul roads on understory plant richness and composition in managed forest landscapes in Upper Michigan, USA. *Forest Ecology and Management* 175: 509–520.
- Cambi, M., Y. Hoshika, B. Mariotti, E. Paoletti, R. Picchio, R. Venanzi, E. Marchi. 2017. Compaction by a forest machine affects soil quality and *Quercus robur* L. seedling performance in an experimental field. *Forest Ecology and Management*. 484: 406-414
- Clerkx, A.P.P.M., M.J. Schelhaas, J. Zwart. 2015. *Oogst in het Nederlandse bos. Analyse van niet geogste plots uit de Zesde Nederlandse Bosinventarisatie*. Alterra-rapport 2610. Wageningen, Alterra.
- De Baaij, G. 1999. 1974: 25 jaar actuele mechanisatie. *Nederlands Bosbouw Tijdschrift*. 71 (1): 34-34.
- Demir, M., E. Makineci, B.S. Gungor. 2008. Plant Species Recovery on a Compacted Skid Road. *Sensors*. 8 (5): 3123–3133.
- De Schrijver, A. de, E. Ampoorter, R. van der Burg, A. Demey, S. Schelfhout, A. Olsthoorn, P. De Smet, P. Vangansbeke, L. Van Nevel, P. Hommel, P. De Frenne, J. Mertens, K. Verheyen.

2018. Groeiplaatsverbetering. pp. 64-97 In: P. Jansen, M. Boosten, M. Cassaert, E. Thomassen, M. Winnock (Red.). 2018. *Praktijkboek bosbeheer*. Wageningen, Stichting Probos & Inverde.
- Dickerson, B.P. 1976. Soil Compaction After Tree-Length Skidding in Northern Mississippi. *Soil Science Society of America Journal*. 40 (6): 965-966.
- Ebeling, C., F. Lang, T. Gaertig. 2016. Structural recovery in three selected forest soils after compaction by forest machines in Lower Saxony, Germany. *Forest Ecology and Management*. 359 (2016): 74-82.
- Fisher, R.F., D. Binkley. 2000. *Ecology and management of forest soils*. Wiley, New York.
- Frey, B., J. Kremer, A. Rüdter, S. Sciacca, D. Matthies, P. Lüscher. 2009. Compaction of forest soils with heavy logging machines affects soil bacterial community structure. *European Journal of Soil Biology* 45 (4): 312-320.
- Frey, B. 2010. Bewertung von befahrungsbedingten Bodenveränderungen mittels Bakterienpopulationen. *Schweizerische Zeitschrift für Forstwesen*. 161 (12): 498-503.
- Frutig, F., P. Lüscher. 2015. Was bringt das Rücken mit halber Ladung? *Wald und Holz*. 96 (8): 49-52.
- Frutig, F., O. Thees, P. Ammann, P. Lüscher, P. Rotach. 2016. Holzerntekosten und Minderlöse bei verschiedenen Rückegassenabständen in Fichtenbeständen. *Schweizerische Zeitschrift für Forstwesen*. 167 (2): 64-72.
- Gebhardt, S., H. Fleige, R. Horn. 2009. Effect of compaction on pore functions of soils in a Saalean moraine landscape in North Germany. *Journal of Plant Nutrition and Soil Science*. 172 (5): 688-695.
- Godefroid, S., N. Koedam. 2004. The impact of forest paths upon adjacent vegetation: effects of the path surfacing material on the species composition and soil compaction. *Biological Conservation* 119: 405-419.
- Goris, R. 2018. Bosexploitatie. pp. 320-365. In: P. Jansen, M. Boosten, M. Cassaert, E. Thomassen, M. Winnock (Red.). 2018. *Praktijkboek bosbeheer*. Wageningen, Stichting Probos & Inverde.
- Goutal, N., P. Renault, J. Ranger. 2013. Forwarder traffic impacted over at least four years soil air composition of two forest soils in northeast France. *Geoderma*. 193-194: 29-40.
- Greacen E.L., Sands R. 1980. Compaction of forest soils. A review. *Australian Journal of Soil Research*. 18 (2): 163-189.
- Grüll, M. 2011. Den Waldboden schonen – Vorsorgender Bodenschutz beim Einsatz von Holzerntetechnik. *Eberswalder Forstliche Schriftenreihe*. 47: 37-44.
- Grüll, M. 2013. Standortsangepasstheit von Holzernteverfahren. *AFZ-DerWald*. 68 (18): 30-32.

- Halvorson J.J., L.W. Gatto, D.K. McCool. 2003. Overwinter changes to near-surface bulk density, penetration resistance and infiltration rates in compacted soil. *Journal of Terramechanics*. 40 (1): 1-24.
- Hartkopf, A. 2018. Sanfter Riese. *Forst und Technik*. 2018 (9): 24-25.
- Hauck, B. 2001. Aspekte des Bodenschutzes bei der Entwicklung, beim Kauf und dem Einsatz von Forstmaschinen. *Forsttechnische Informationen*. 4:41-46.
- Heninger, R., W. Scott, A. Dobkowski, R. Miller, H. Anderson, S. Duke. 2002. Soil disturbance and 10-year growth response of coast Douglas-fir on nontilled and tilled skid trails in the Oregon Cascades. *Canadian Journal of Forest Research*. 32 (2) 233-246.
- Herbauts, J., J.E. Bayad, W. Gruber. 1996. Influence of logging traffic on the hydromorphic degradation of acid forest soils developed on loessic loam in middle Belgium. *Forest Ecology and Management*. 87: 193-207.
- Heubaum, F. 2015. Bodenscherfestigkeit auf Rückegassen. *Forst & Technik*. 8: 18-22.
- Hillel, D. 1998. *Environmental soil physics*. San Diego, Academic Press.
- Howard, R.F., M.J. Singer, G.A. Frantz, 1981. Effects of soil properties, water-content, and compactive effort on the compaction of selected California forest and range soils. *Soil Science Society of America Journal*. 45: 231-236.
- Ireland, D. 2006. *Traction Aids in Forestry. Technical note*. Edinburgh, Forestry Commission.
- Jansen, P., M. van Benthem, C. de Groot, M. Boosten. 2012. *Cultural heritage in sustainable forest management. The Dutch perspective*. Wageningen, Stichting Probos.
- Kaufmann, G., P. Lüscher. 2007. Mechanische Belastung von Waldböden. *Wald und Holz*. 88 (2): 32-33.
- Kietz, B., R. Riggert, F. Bombosch, R. Nollau, T. Gaertig. 2017. Spannungseinträge in den Boden unter Holzerntemaschinen. *AFZ-DerWald*. 72 (6): 41-45.
- Kooistra, M.J., G.J. Maas. 2008. The widespread occurrence of Celtic field systems in the central part on the Netherlands . *Journal of Archaeological Science*. 35; 2318-2328.
- Kozlowski, T.T. 1999. Soil Compaction and Growth of Woody Plants. *Scandinavian Journal of Forest Research*. 14 (6): 596-619.
- Kremer, J., D. Matthies, B. Wolf, G. Ohrner, E. Uhl. 2003. Bodenstrukturveränderungen und Wurzelverletzungen. *AFZ/DerWald*. 17. 847-850.
- Kremer, J., E. Uhl, G. Ohrner, D. Matthies, C. Ganter. 2005. Besserer Boden- und Bestandesschutz beim Einsatz von Raupenharvestern. *Forsttechnik*. 14: 729 -731.
- Kremer, J., B. Wolf, D. Matthies, H. Borchert. 2012. *Bodenschutz beim Forstmachineneinsatz*. Oberbergkirchen, Druckerei Lanzinger.

- Kremer, J., M. Schardt. 2014. Vergleich der Bogiebänder Eco-Track und Eco-Baltic mit Reifen. [Waldwissen.net](http://Waldwissen.net)
- Labelle, E.R. 2017. *Machine and soil interactions: Overview of the impacts and mitigation techniques in forestry*. Presentation Wood Industry Summit – Ligna Hannover, Germany May 24, 2017.
- Labelle, E.R., D. Jaeger. 2011. Soil Compaction Caused by Cut-to-Length Forest Operations and Possible Short-Term Natural Rehabilitation of Soil Density. *Soil Science of America Journal*. 75 (6): 2314-2329.
- Lousier J.D. 1990. *Impacts of forest harvesting and regeneration on forest sites*. Victoria B.C., BC Ministry of Forests.
- Lüscher, P. 2010. Bodenveränderungen und Typisierung von Fahrspuren nach physikalischer Belastung. *Schweiz Zeitschrift für Forstwesen*. 161 (12): 504-509.
- Lüscher, P., F. Frutig, S. Sciacca, S. Spjevak, O. Thees. 2010. Physikalischer Bodenschutz im Wald. Bodenschutz beim Einsatz von Forstmaschinen. *WSL Merkblatt für die Praxis*. 45.
- Lüscher, P., F. Frutig, O. Thees. 2005. Physikalischer Bodenschutz im Wald ist kein Luxus. *Zürcher Wald*. 2005 (6): 10-13.
- Lüscher, P., F. Frutig, O. Thees. 2016. *Physikalischer Bodenschutz in Wald. Waldbewirtschaftung in Spannungsfeld zwischen Wirtschaftlichkeit und Erhaltung der physikalischen Bodeneigenschaften*. Bern, Bundesamt für Umwelt.
- Makineci E., B.S. Gungor, M. Demir. 2008. Survived herbaceous plant species on compacted skid road in a fir (*Abies bornmulleriana* Mattf.) forest – A note. *Transportation Research Part D* 13: 187–192.
- Malmer, A., H. Grip. 1990. Soil disturbance and loss of infiltrability caused by mechanized and manual extraction of tropical rainforest in Sabah, Malaysia. *Forest Ecology and Management*. 38:1-12.
- Matthies, D. 2009. Forsttechnik unter Druck. *LWF aktuell*. 68: 47-49.
- McNabb, D.H., L. Boersma. 1993. Evaluation of the relationship between compressibility and shear strength of Andisols. *Soil Science Society of America Journal*. 57 (4): 923-929.
- Meyer, C., P. Lüscher, R. Schulin. 2011. Verdichteten Boden mit Schwarzerlen regenerieren? *Wald und Holz*. 92 (10): 40-43.
- Naghdi R., A. Solgi, E.K. Zenner, F.K. Behjou. 2018. Soil physical properties degrade further on skid trails in the year following operations. *Journal of Forestry Research*. 29 (1): 93-101.
- Potvliet, G. 2016. *Impact van gemachineerde houthoogst op de bosbodem & effecten van het werken met dunningspaden*. s.l., Bosgroep Midden Nederland.

- Potvliet, G., W. Delforferie. 2016. Nooit meer van de gebaande paden? Permanente dunningspaden als mogelijk oplossing voor het beperken van bodemverdichting. *Vakblad Natuur Bos Landschap*. 13 (122): 3-5.
- Ruzicka, K., K. Ljung, S. Vanneste, R. Podhorska, T. Beeckman, J. Frimi, E. Benkova. 2007. Ethylene regulates root growth through effects on Auxin biosynthesis and transport-dependent Auxin distribution. *The Plant Cell*. 19 (7): 2197-2212.
- Schack-Kirchner, H. 2010. 30 Jahre Forschung zur Bodenverformung durch Forstmaschinen in Deutschland. *AFZ-DerWald*. 65 (18): 14-16.
- Schäffer, J. 2002. Befahren von Waldböden – ein Kavaliersdelikt? *Der Waldwirt*. 29 (12), 21-23.
- Schelhaas, M.J., A.P.P.M. Clerkx, W.P. Daamen, J.F. Oldenburger, G. Velema, P. Schnitger, H. Schoonderwoerd, H. Kramer. 2014. *Zesde Nederlandse Bosinventarisatie: methoden en basisresultaten. Alterra-rapport 2545*. Wageningen, Alterra.
- Siepel, H. 2015. De rol van bodemfauna in oude bosbodems. *Vakblad Natuur Bos Landschap*. 12 (112): 23-25.
- Silversides, C.R., U. Sundberg. 1996. *Operational Efficiency in Forestry. Volume 2: Practice*. Dordrecht, Kluwer Academic Publishers Group.
- Šimon, J., J. Lhotský . 1989. *Zpracování a zúrodnění půd (Treatment and fertilization of soils)*. Prague, SZN Praha.
- Staatsbetrieb Sachsenforst. 2006. *Holzerntetechnologien. Richtlinie zur Anwendung im Staatswald des Freistaates Sachsen*. Pirna, Staatsbetrieb Sachsenforst.
- Stewart, R.A. 1986. *An economic model of soil compaction in forestry*. College of Forestry. Oregon State University.
- Sutherland, B.D. 2003. *Preventing soil compaction and rutting in the boreal forest of Western Canada. A Practical Guide to Operating Timber-Harvesting Equipment*. Point Claire, Forest Engineering Research Institute of Canada (FERIC).
- Tardieu, F., J. Zhang, N. Katherji, O. Bethenod, S. Palmer, W.J. Davies. 1992. Xylem ABA controls the stomatal conductance of field-grown maize subjected to soil compaction or soil drying. *Plant, Cell and Environment*. 15 (2): 193-197.
- Teepe, R., R. Brumme, F. Beese, B. Ludwig. 2004. Nitrous Oxide Emission and Methane Consumption Following Compaction of Forest Soils. *Soil Science Society of America Journal*. 68(2): 605-611.
- Thate, J.B. 1973. Mechanisatie van de houtoogst in Nederland. *Nederlands Bosbouw Tijdschrift*. 45 (3). 78-88.
- Torbert, H.A., C.W. Wood. 1992. Effects of soil compaction and water-filled pore space on soil microbial activity and N losses. *Communications in Soil Science and Plant Analysis*. 23 (11): 1321-1331.

Uhl, E., G. Ohrner, D. Matthies, H. Kremer, B. Wolf. 2003. Einsatzempfehlungen für Rad- und Raupenfahrwerke. *LWF aktuell*. (39): 11-14.

Ulrich R, A. Schlaghamerský, V. Štorek. 2003. *Using harvesters in thinnings*. Brno, Mendel University.

Vermeulen, G.D., B.R. Verwijs. 2007. *Inventarisatie van beschikbare techniek voor oogst en transport met lage bodemdruk*. Wageningen, Plant Research International.

Wehner, T., H. Jacke, R. Dreeke. 2010. Realitäten und Visionen beim bodenverträglichen Einsatz von Forstmaschinen. *AFZ-DerWald*. 65 (18): 24-27.

Weise, G. 2008. Entwicklung und Einsatz von Forstreifen. *LWF aktuell*. 67: 24-27.

Wert, S., B.R. Thomas. 1981. Effects of skid roads on diameter, height and volume growth in Douglas-fir. *Soil Science Society of America Journal*. 45 (3): 629-632.

Wispelwey, M. 2010. Grafheuvels in een prehistorisch landschap. *Vakblad Natuur Bos Landschap*. 7; 1, 14-15.

Ziesak, M. 2004. *Entwicklung eines Informationssystems zum bodenschonenden Forstmaschineneinsatz*. Munich, Technical University of Munich.